



simufact additive

Version 4.0

What's new?

Hamburg, November 30th 2018



Simulating manufacturing - the manufacturing division of MSC Software



- ◆ more than 20 years of experience
- ◆ more than 70 experts
- ◆ more than 700 customers

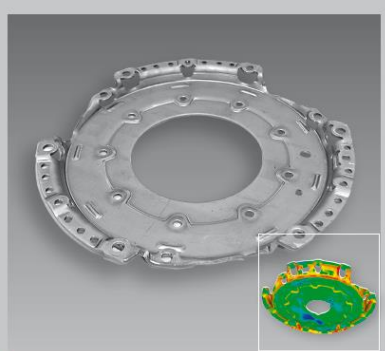









simufact forming
Forming Simulation



simufact additive
Additive Manufacturing Simulation









simufact welding
Welding Simulation

 Cold Forming	 Hot Forging	 Sheet Metal Forming	 Mechanical Joining
 Rolling	 Ring Rolling	 Open Die Forging	 Heat Treatment



Powder Bed Fusion

 Arc Welding	 Laser Beam	 Electron Beam	
 Resistance Spot Welding	 Brazing	 Stress Relief	 Metal Deposition

- ◆ Supporting the optimization of **metal-based manufacturing** processes
- ◆ Manufacturing-oriented process simulation
- ◆ Special adapted **SF-MARC** non-linear finite element solver technology based on **MSC MARC**

What's new? – Highlights

- ◆ Support optimization with respect to distortion minimization and support volume reduction
- ◆ Calibration with user-defined geometry and settings
- ◆ Spatially dependent inherent strains
- ◆ Mapping to tet/hex mesh for UNV export
- ◆ Updated solver based on MSC Marc 2018
- ◆ Many improvements in usability & stability

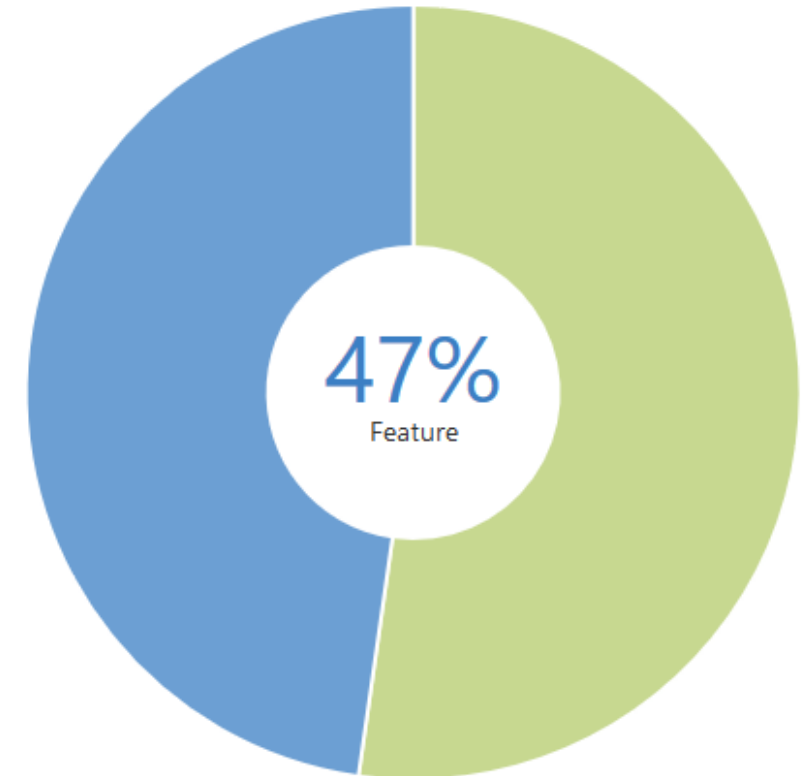

Implemented development tasks 243

 Bug	127
 Feature	116

Support optimization

- ◆ One of the **most challenging tasks** during the build preparation is to **find the optimal support structures**
- ◆ Supports are mainly created based on geometric properties like angle, overhang distance etc.
- ◆ They act like anchors and hold the geometry in position during the build stage
- ◆ Thus there is potential to **optimize the support structures automatically** with respect to:
 - ◆ Reducing the support volume and therefore costs
 - ◆ Reducing the distortions of the geometry
 - ◆ Find supports that are optimal suited for the acting mechanical loads

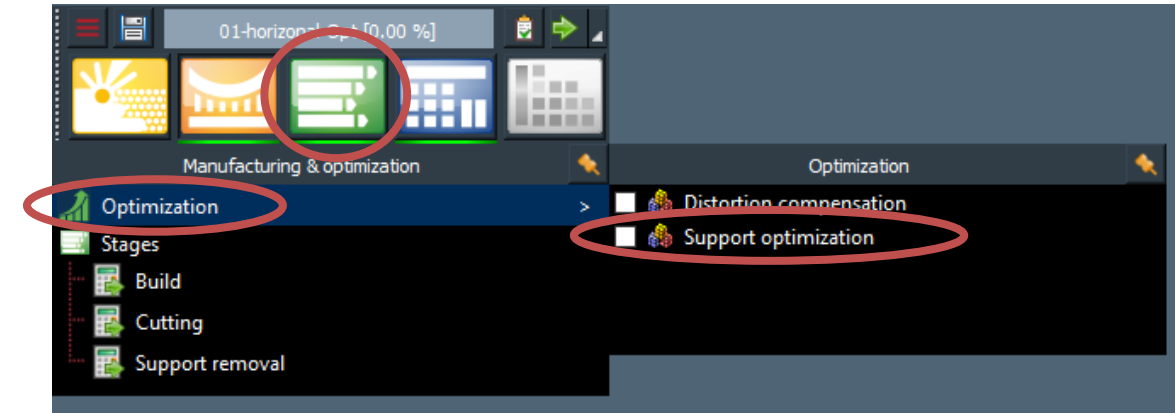

Support optimization

- ◆ The **support optimization** is integrated as a **fully automatic solution** and takes the loads during the build stage into account
- ◆ The optimization is done in two steps:
 - ◆ Simulate the part without supports to determine the mechanical loads
 - ◆ Optimize the supports with respect to the mechanical loads from the previous process and perform the simulation
- ◆ The minimum support radius as well as the minimum volume fraction can be used to control how and where supports should be created
- ◆ In addition to the optimized supports, the angle-based supports can be added as well if needed

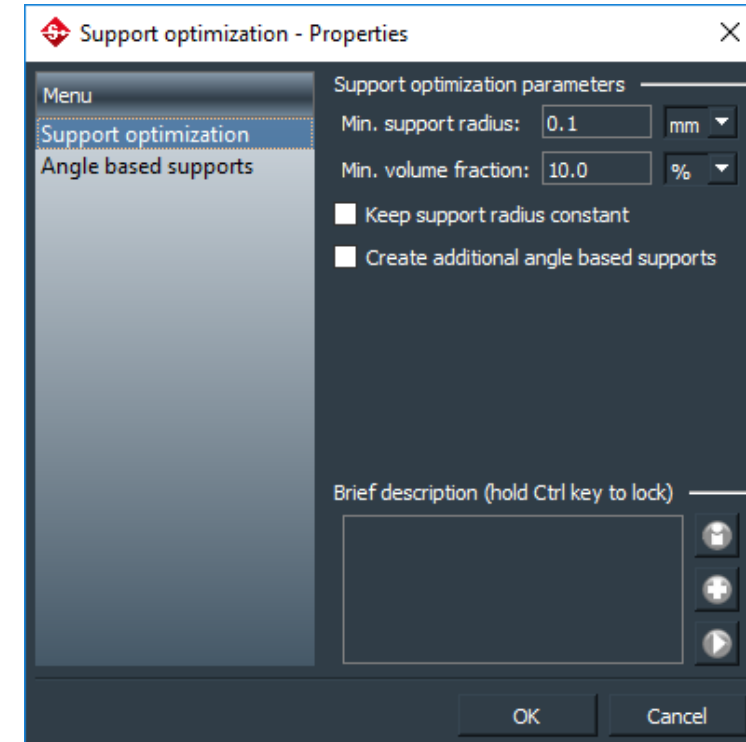

Support optimization

- ◆ Two different methods are available for the support optimization:
 - ◆ Change the support radius according to the mechanical loads (default)
 - ◆ Change the number of supports for a defined area according to the mechanical loads

Method 1

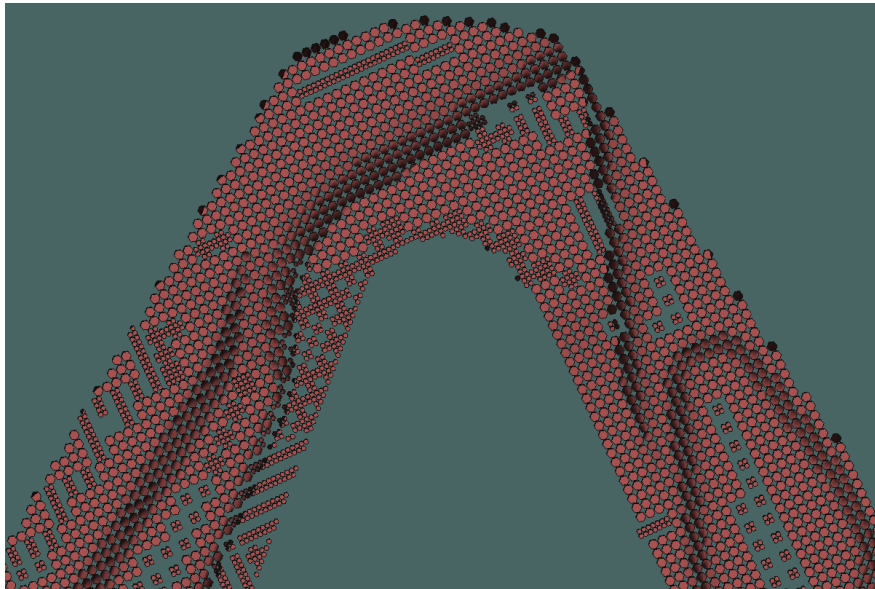

Method 2

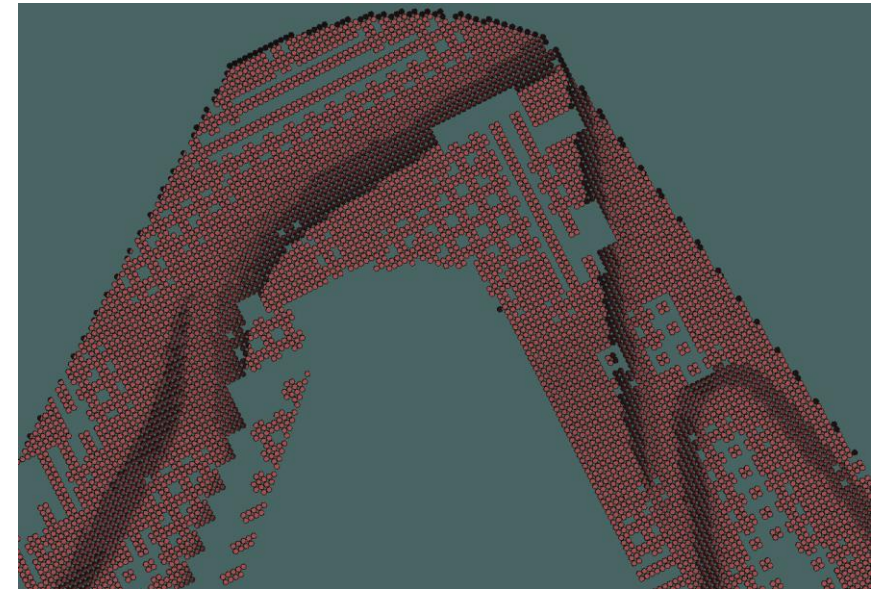

- ◆ The mechanical calibration process is essential for accurate results in the simulation
- ◆ Thus the workflow was completely re-designed to allow a better user experience
- ◆ For a fast and easy mechanical calibration everything needed is pre-defined in the GUI:
 - ◆ Single cantilever geometry
 - ◆ Uniform & isotropic inherent strains
 - ◆ Measuring point
 - ◆ Cutting stage

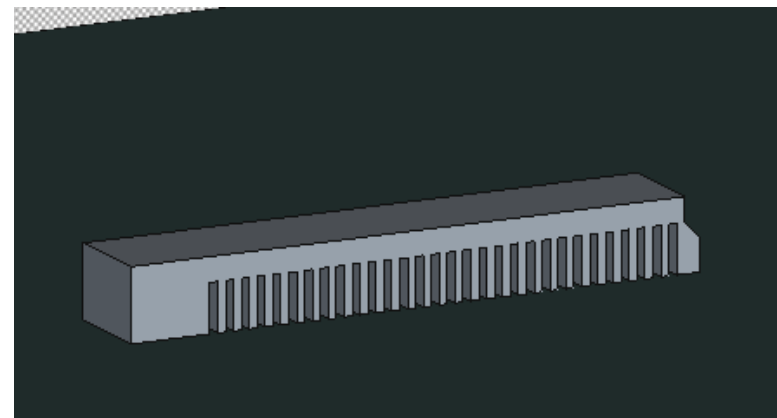
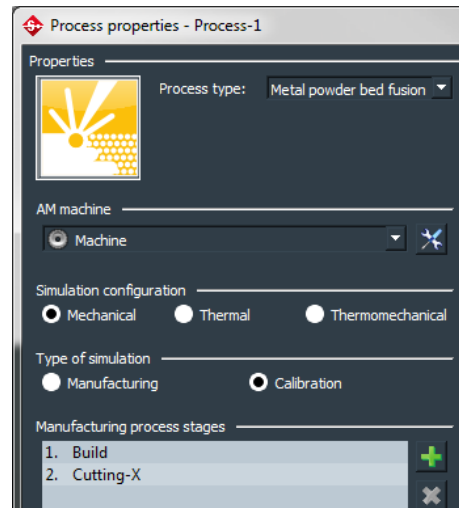

User-defined calibration – mechanical

- ◆ Inherent strains are by default uniform and isotropic – most simple case!
- ◆ For more advanced purposes the strains can be changed to orthotropic and distributed (depending on the location on the base plate)
- ◆ It can be saved if the scanning pattern was rotated during manufacturing of the cantilever
 - ◆ Has no influence on the calibration
 - ◆ Allows a more simple workflow for the normal build simulation

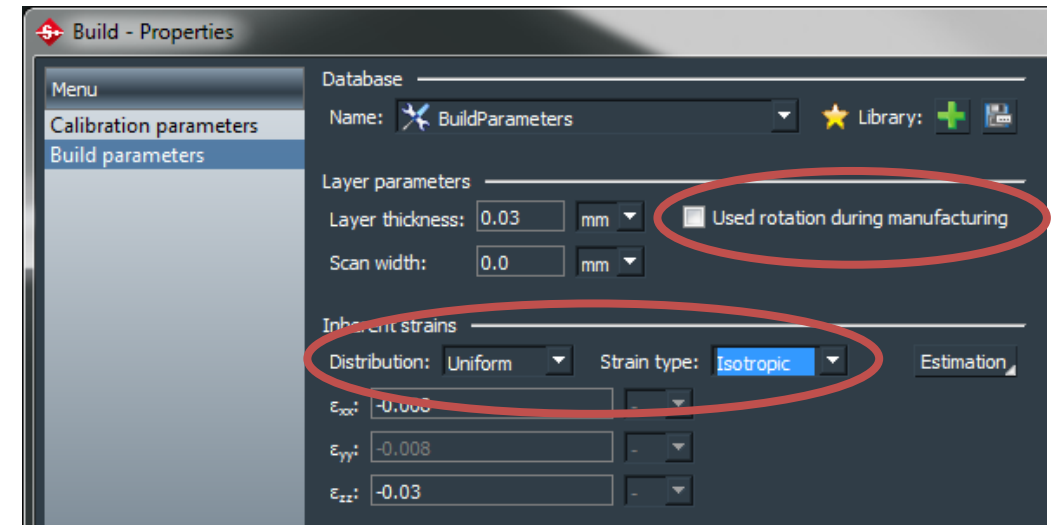

User-defined calibration – mechanical

- ◆ One measuring point is pre-defined when creating a calibration process
- ◆ More calibration points can be added

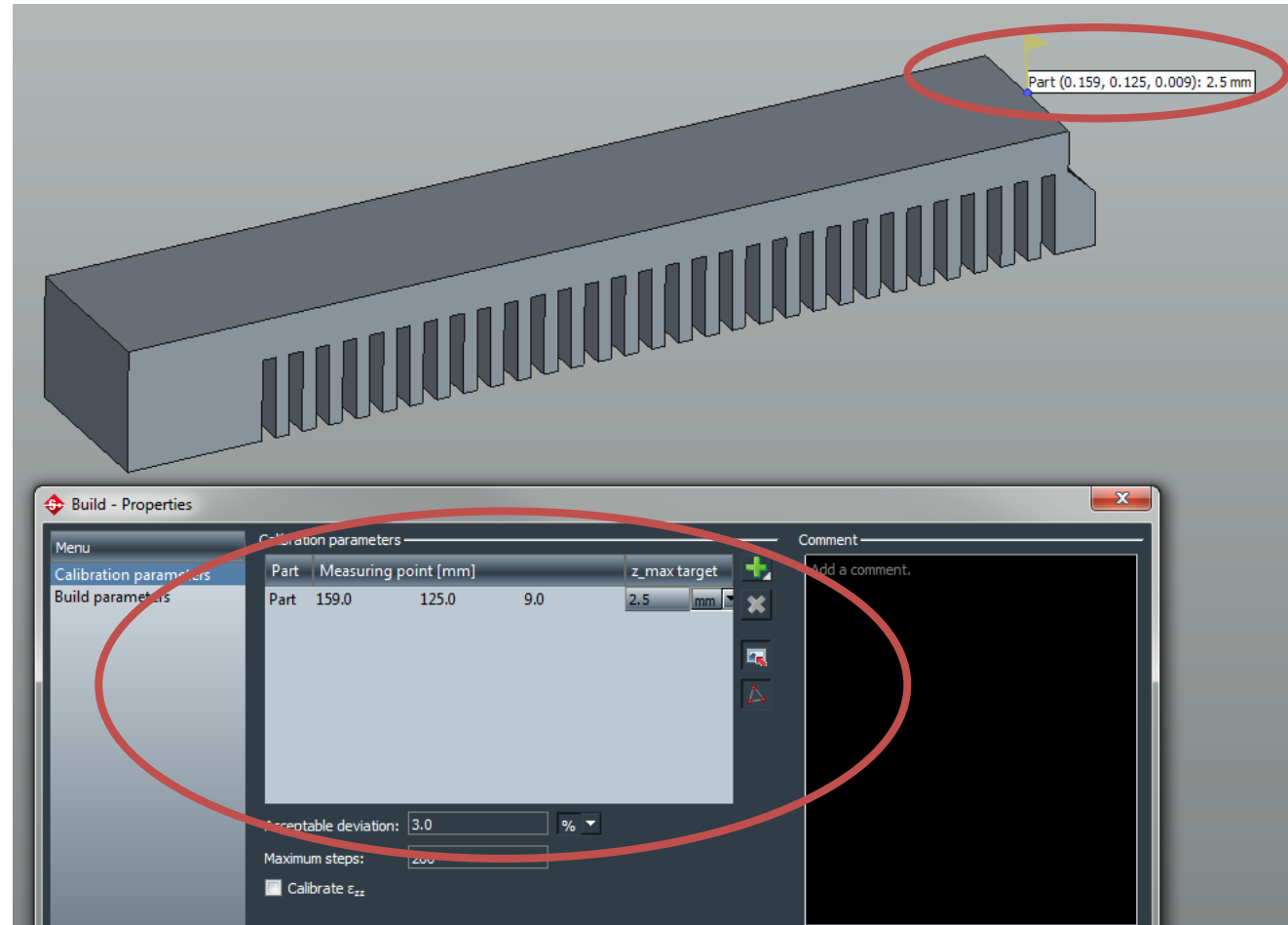
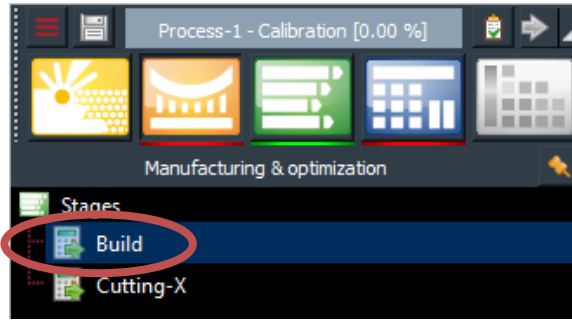

User-defined calibration – mechanical

- ◆ One cutting stage pre-defined in X direction

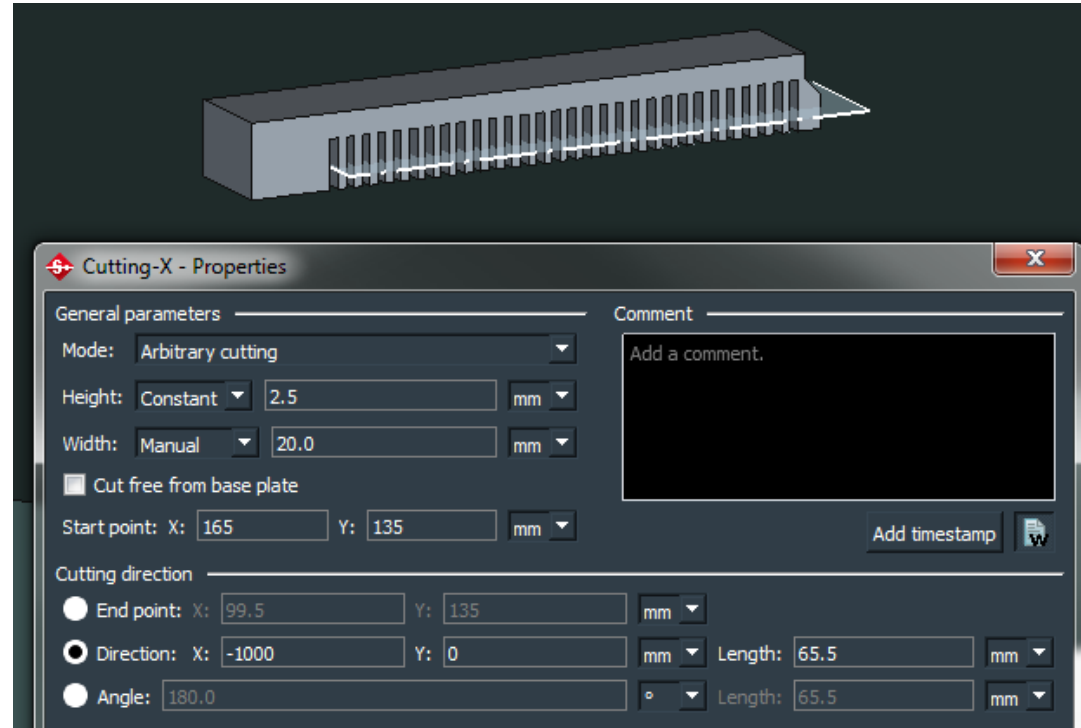
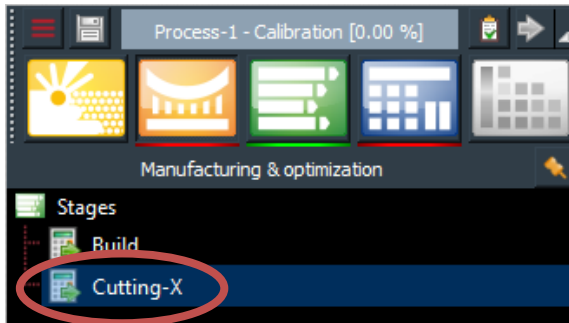

Summary mechanical calibration

- ◆ The new standard calibration was designed to achieve a better understanding of the minimum needed parameters
- ◆ No rotation of the strains during calibration. If scan patterns rotate this is implicitly included in the calibrated inherent strains. Rotation is only an information that is saved in the database.
- ◆ If the calibration has been performed without rotation of the scan pattern, a rotation can be defined in a later manufacturing simulation. If the calibration has been performed with rotation of the scan pattern, the rotation should not be used in later manufacturing simulation – as it is already implicitly included in the calibrated strain.

User-defined calibration – thermal

- ◆ Thermal processes are now also available for calibration
- ◆ For a thermal process calibration the maximum peak temperature is calibrated by changing the exposure energy fraction

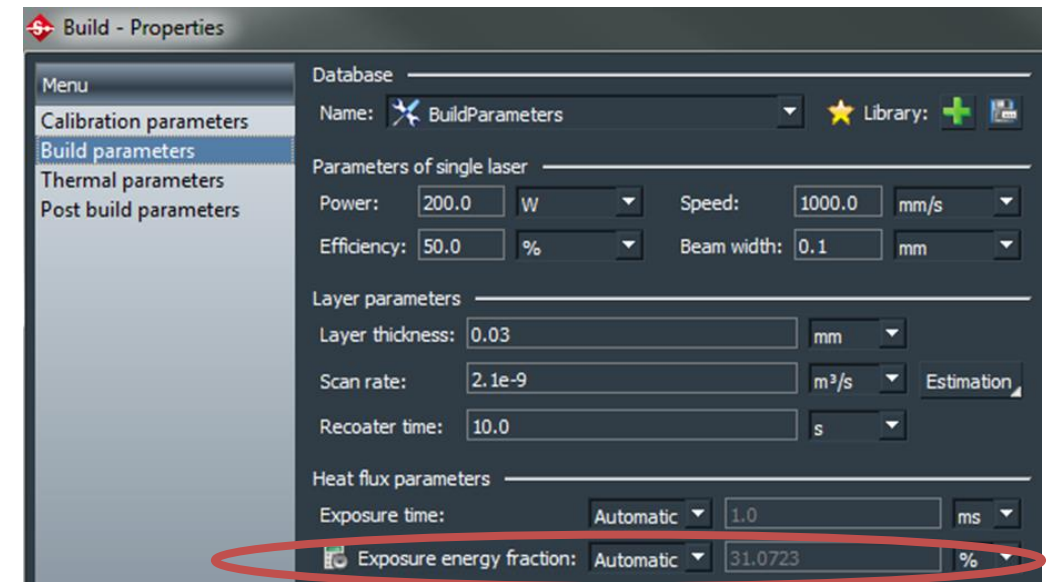
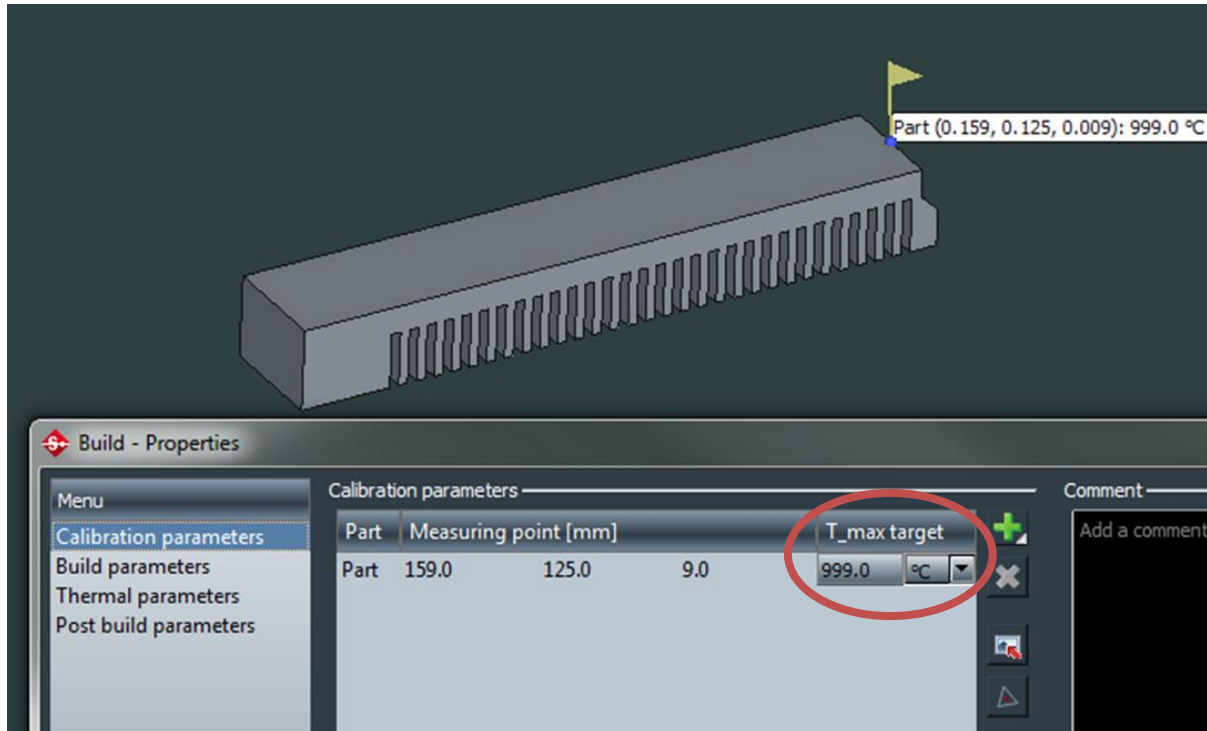
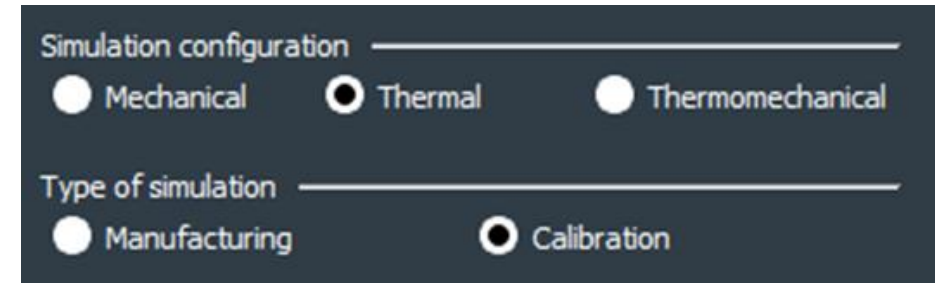

User-defined calibration – thermomechanical

- ◆ Thermomechanical processes are now also available for calibration
- ◆ For a thermomechanical process calibration the maximum Z deformation is calibrated by changing the volumetric expansion factor

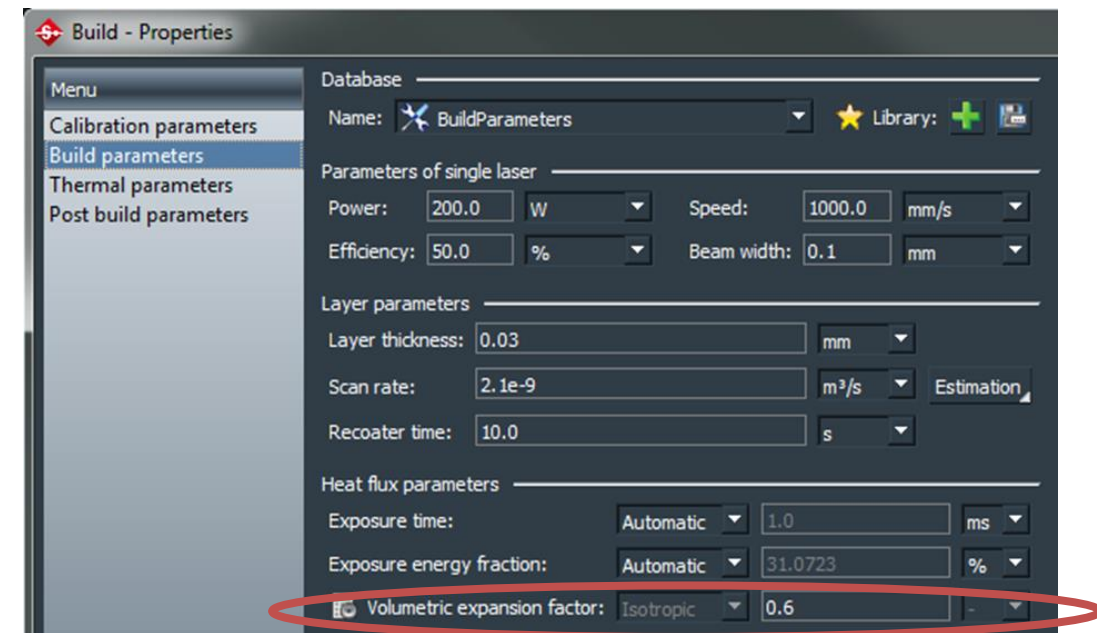
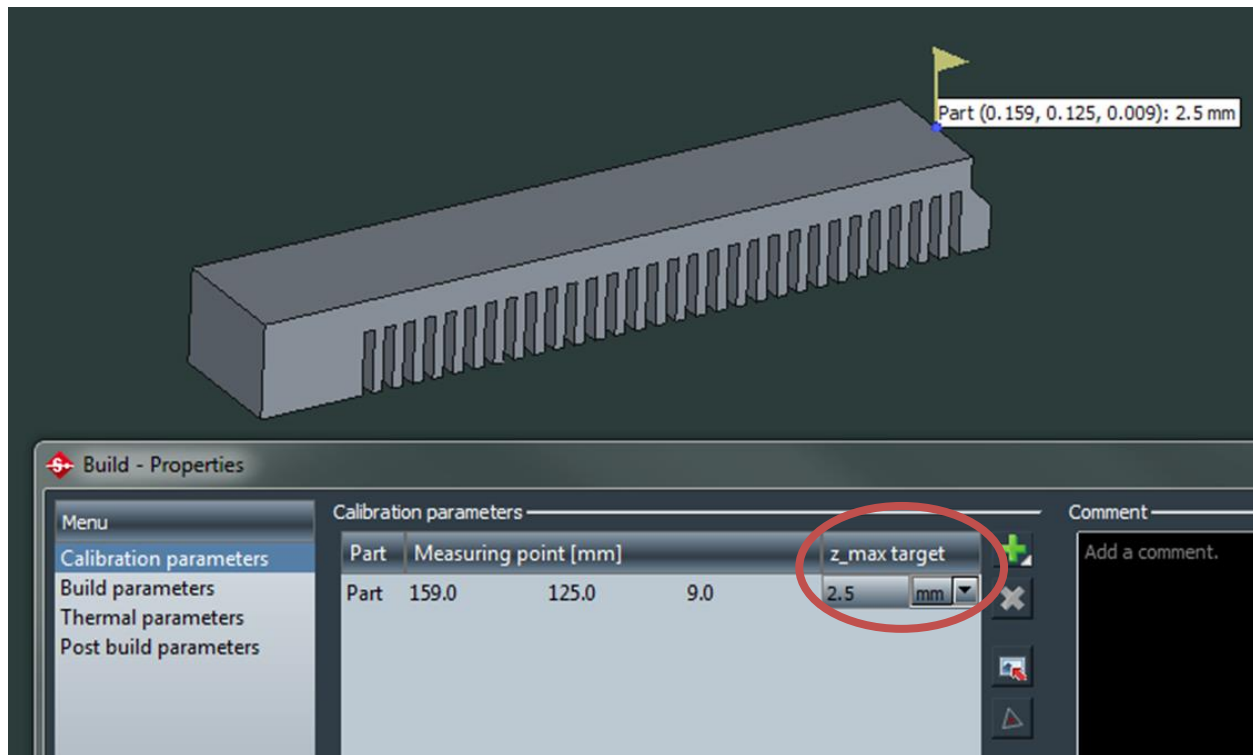
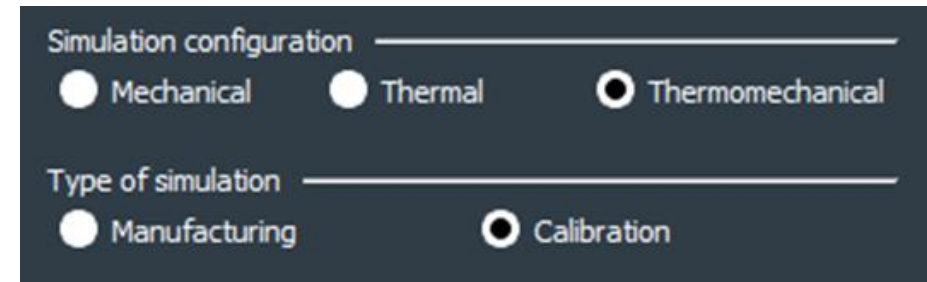

Summary calibration

◆ Besides the new workflow the user has the following new capabilities for calibration:

- ◆ Calibration for mechanical, thermal and thermomechanical processes
- ◆ Import one or multiple geometries → Also includes positioning
- ◆ Use support structures
- ◆ Use base plate during calibration
- ◆ Define multiple measuring points
- ◆ Define orthotropic inherent strains
- ◆ Define spatially dependent inherent strains
- ◆ Use multiple cutting stages (**This is also valid for manufacturing simulation!**)
- ◆ Use a free size for the voxel mesh

→ The new calibration behaves identically to a standard manufacturing simulation during process setup

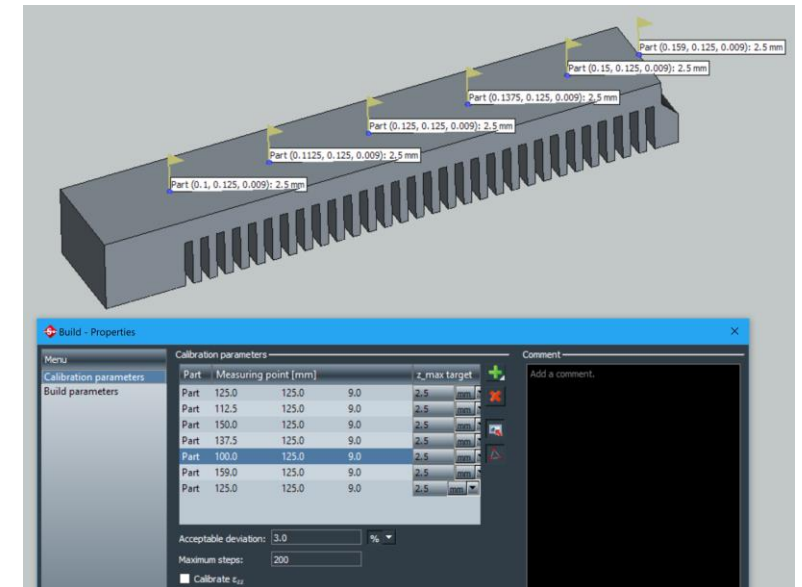
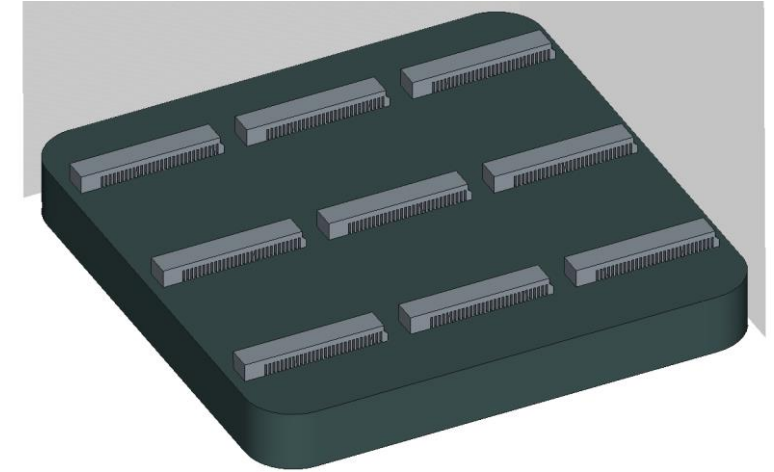

Spatially dependent inherent strains

- ◆ The **inherent strains** can have different values with respect to the **position** of the part on the base plate and height
- ◆ Reasons can be for instance:
 - ◆ Overlapping scanning areas for multi-laser machines
 - ◆ Slightly defocused laser at base plate edges
- ◆ With the current release Simufact Additive can capture these effects during the **mechanical build simulation**
- ◆ The inherent strains can be defined uniformly as in previous versions or spatially dependent
- ◆ The strains can be defined manually, per CSV import or using the calibration for spatially dependent inherent strains
- ◆ This allows to get more accurate results for fully nested base plates and build spaces with the fast approach of the **mechanical build simulation**

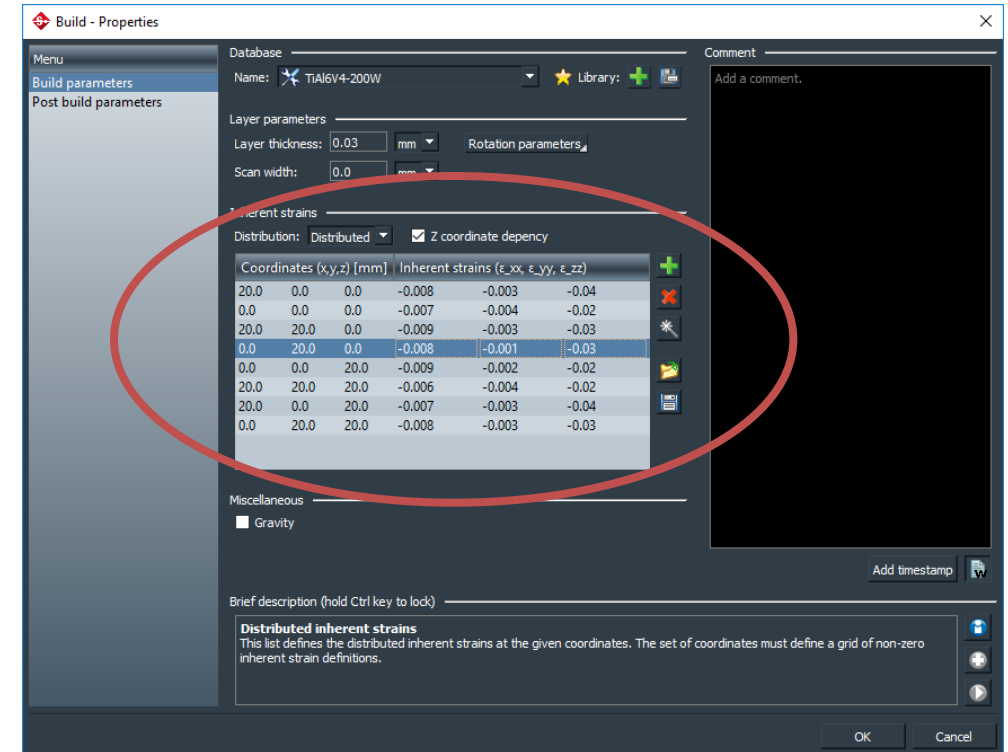

Spatially dependent inherent strains

- ◆ Define or load from database **matrix of local inherent strains** to be used in the simulation
- ◆ Calibrated local inherent strains can reflect different **position-dependent conditions** in the build space
- ◆ Local inherent strains used in the build simulation can be dependent in x, y and z

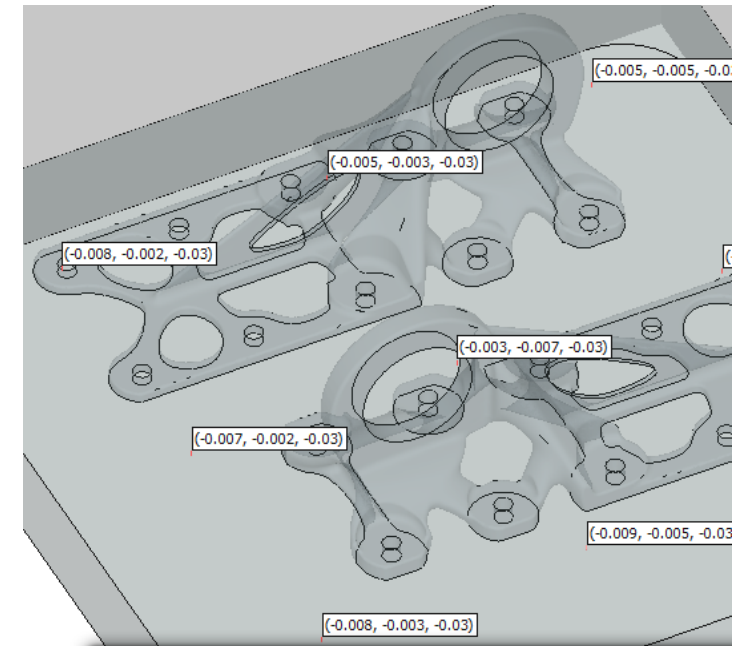

Build - Properties

Database

Name: BuildParameters Library: +

Layer parameters

Layer thickness: 0.03 mm Rotation parameters

Scan width: 0.0 mm

Inherent strains

Distribution: Distributed Z coordinate dependency

Coordinates (x,y) [mm]		Inherent strains (ϵ_{xx} , ϵ_{yy} , ϵ_{zz})		
-83.0	-83.0	-0.008	-0.003	-0.03
-83.0	0.0	-0.007	-0.002	-0.03
-83.0	83.0	-0.008	-0.002	-0.03
0.0	-83.0	-0.009	-0.005	-0.03
0.0	0.0	-0.003	-0.007	-0.03
0.0	83.0	-0.005	-0.003	-0.03
83.0	-83.0	-0.008	-0.005	-0.03
83.0	0.0	-0.006	-0.007	-0.03
83.0	83.0	-0.005	-0.005	-0.03

Spatially dependent inherent strains

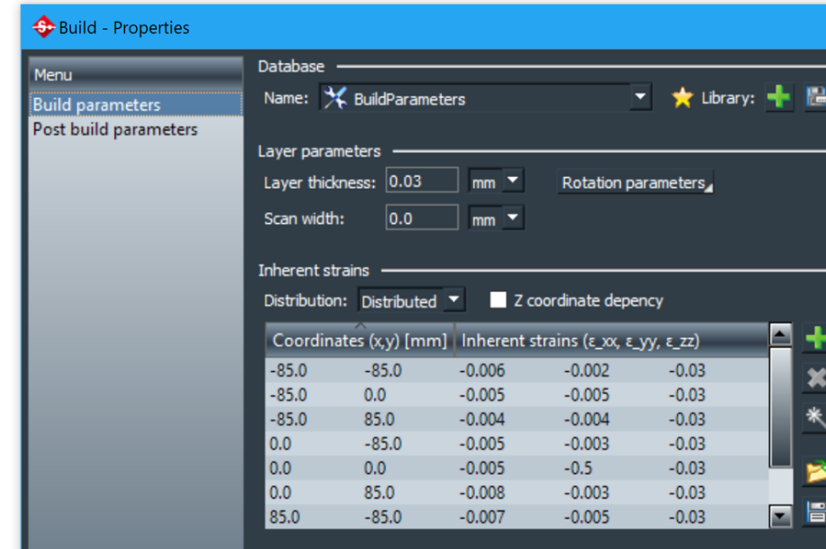
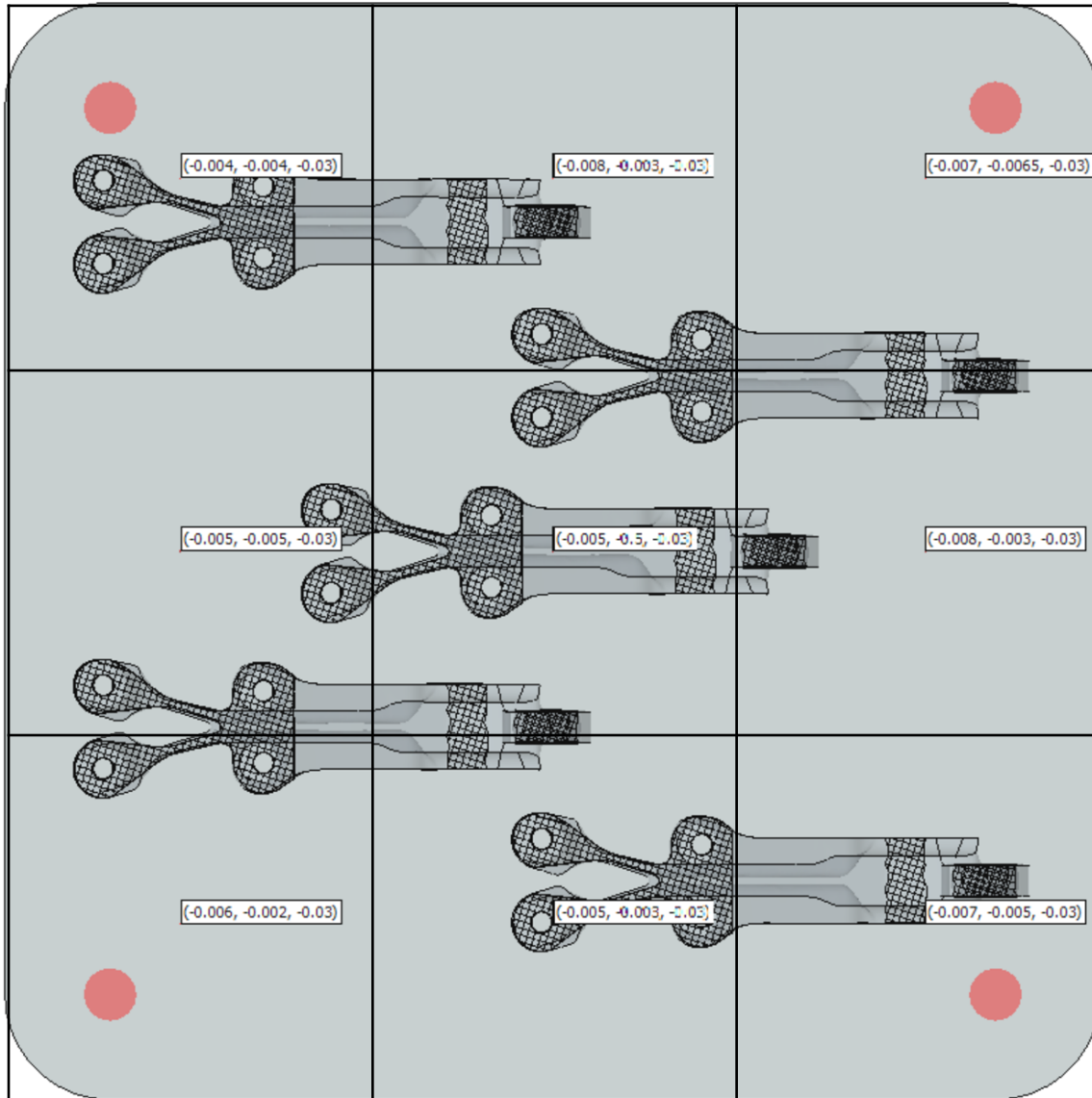

Example

- ◆ 3 x 3 equidistant matrix of inherent strains
- ◆ 1 strain for the center region, 4 strains for the sides, 4 strains for the corners
- ◆ Spatial values will be interpolated between matrix entries
- ◆ Also non-equidistant matrices possible, also in z

Mapping to tet/hex mesh for UNV export

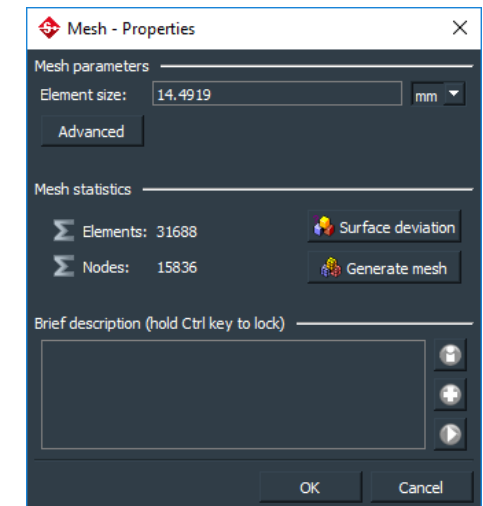
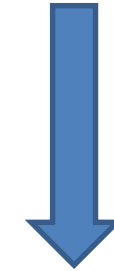
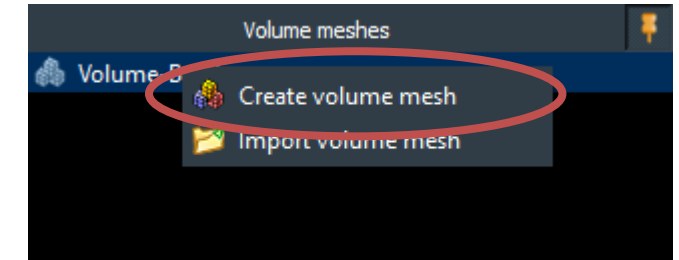
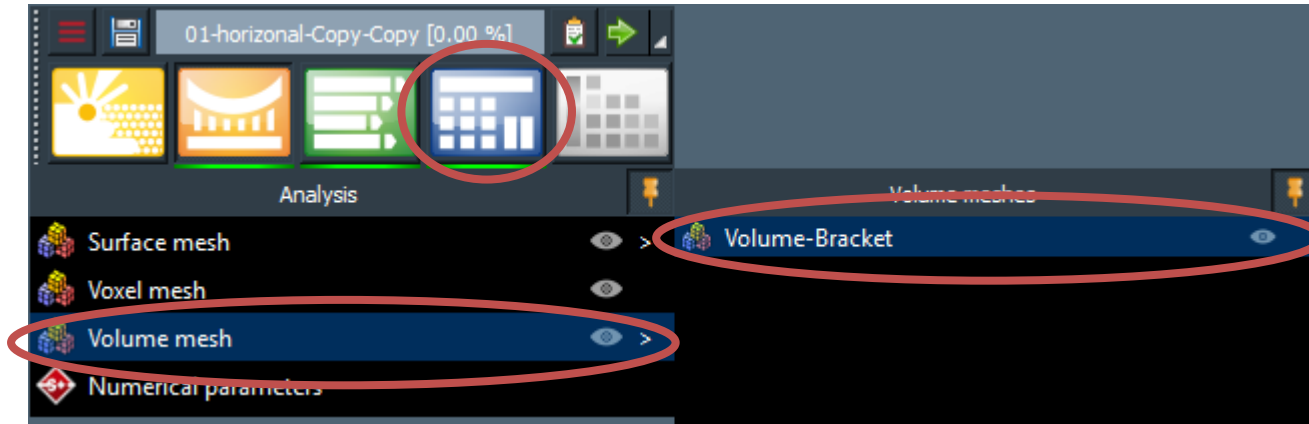

- ◆ UNV export of volume results is possible using volume meshes
- ◆ Every part has a volume mesh container
- ◆ Volume meshes can be created (tet) or imported (tet/hex)

Mapping to tet/hex mesh for UNV export

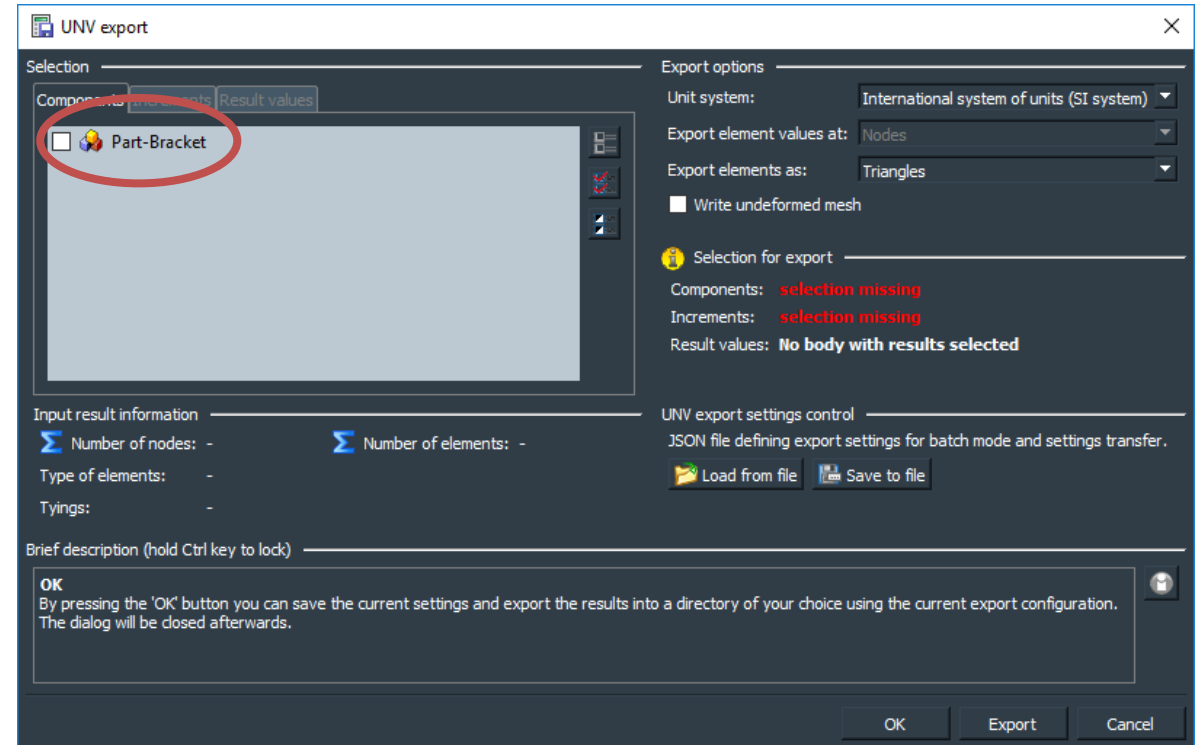
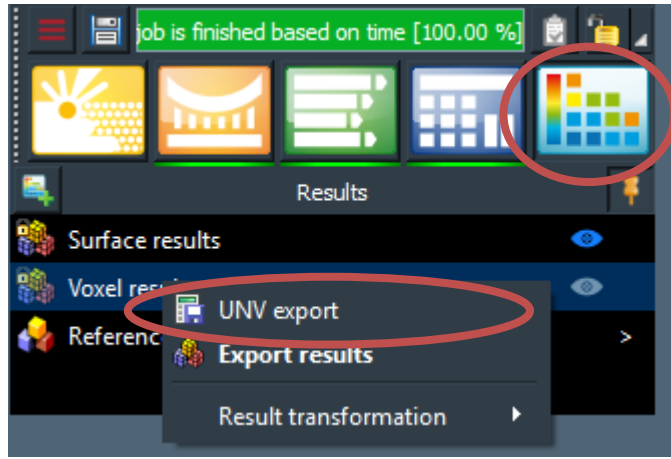

- ◆ The **UNV export** is available on the voxel results in the results widget if a part has a volume mesh assigned
- ◆ **Part names** will be shown in the **UNV export** dialog

Mapping to tet/hex mesh for UNV export

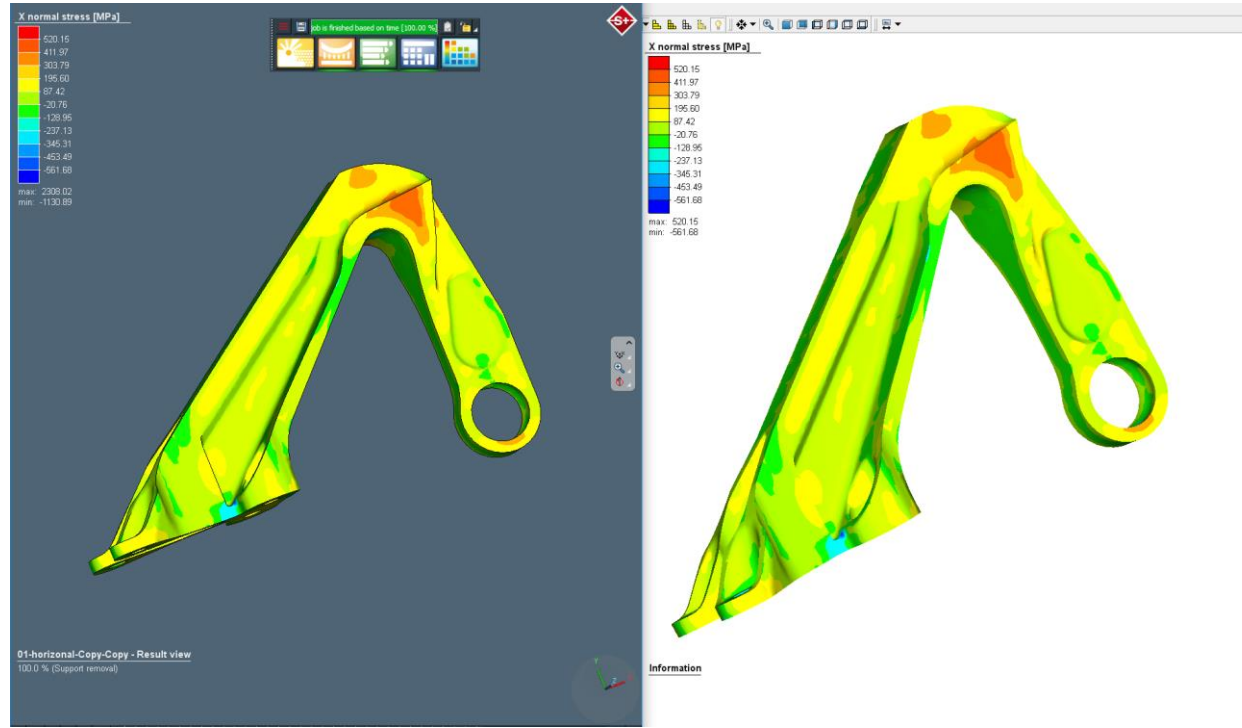

- ◆ UNV file can be imported into 3rd-party software

Updated solver based on MSC Marc 2018

- ◆ sfMarc solver updated to MSC Marc 2018
- ◆ Improved stability for cutting stages and release stages
- ◆ Increased performance → Reduction of simulation time up to 40% compared to previous version

Further improvements

Inventor
SolidWorks
CATIA
Unigraphics
Creo
STEP

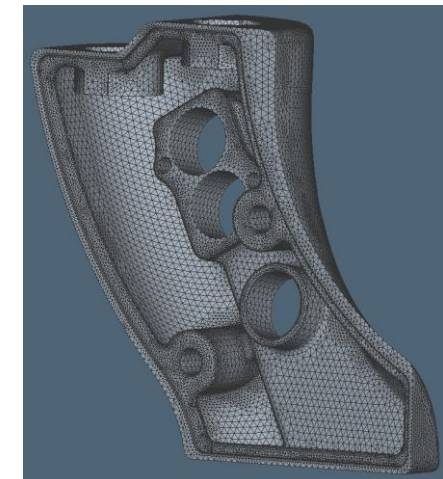
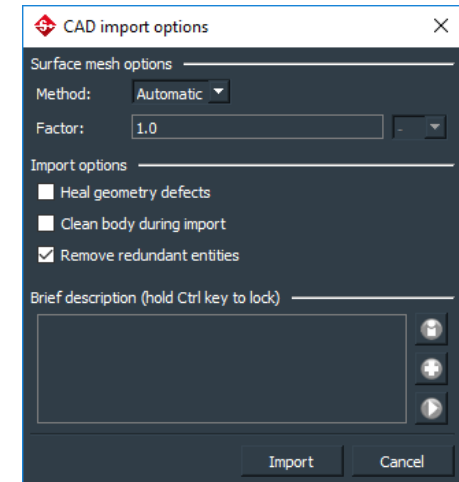
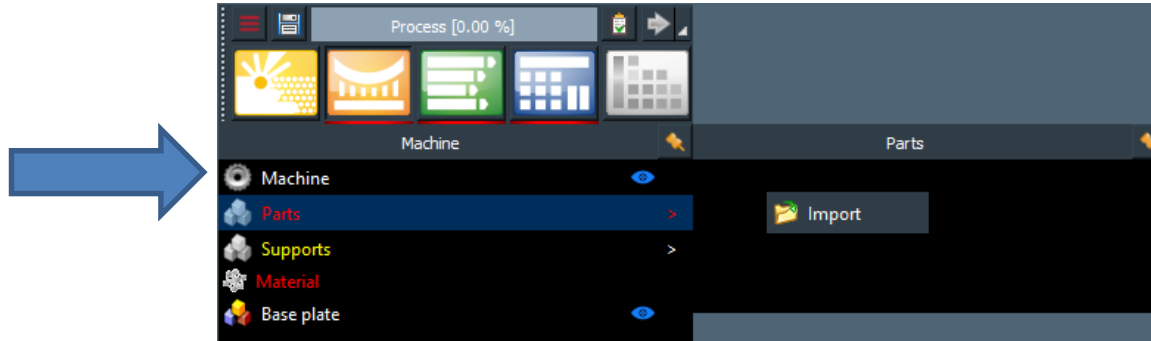

- ◆ **Import of native CAD files**
- ◆ Discretization by surface meshing directly on CAD data
- ◆ Surface remeshing and volume meshing directly on CAD data
- **No loss of geometry information**

Further improvements

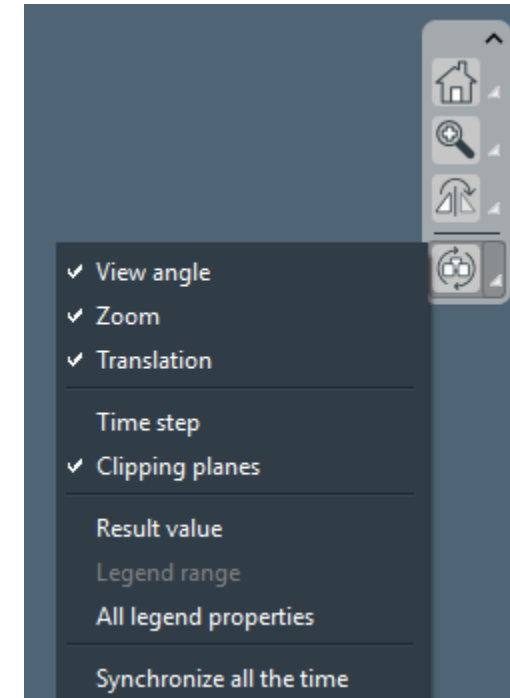
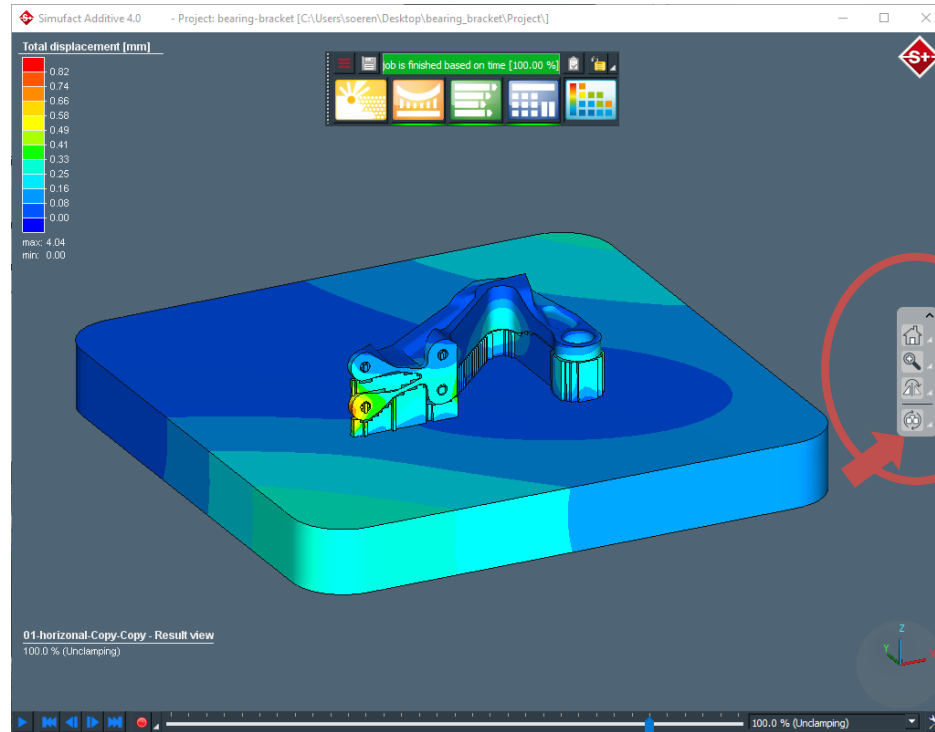

- ◆ Easier and faster view control due to new camera toolbar with main view functions
- ◆ Camera toolbar allows synchronization of multiple views in an easy and fast way

Further improvements

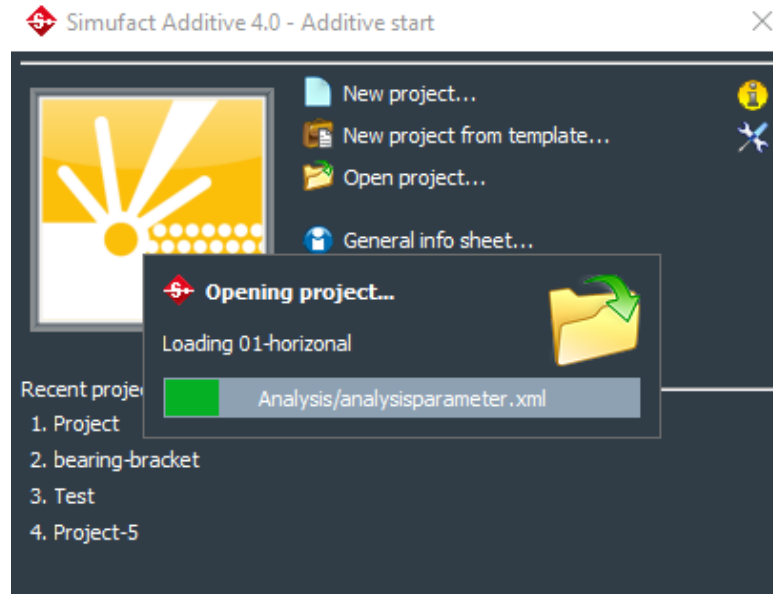

- ◆ A **progress bar** will be shown **when opening a project** to give feedback to the user

Further improvements

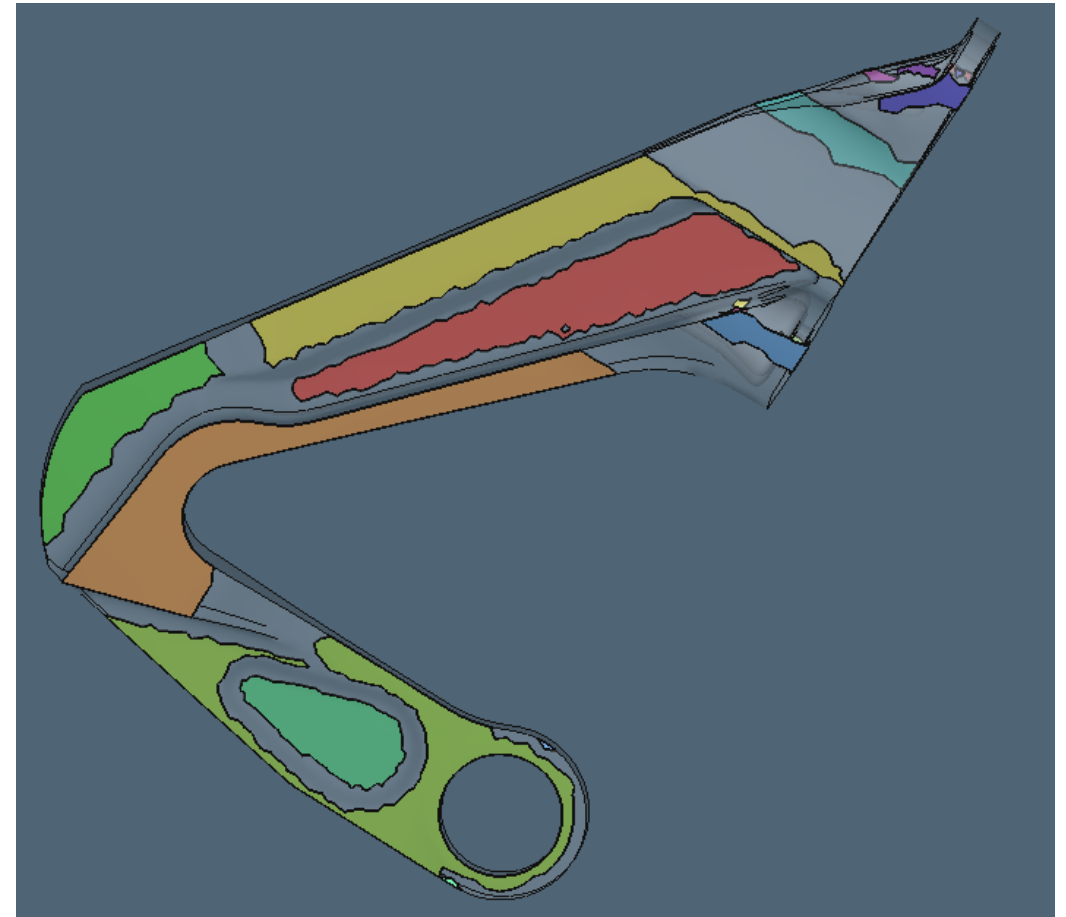
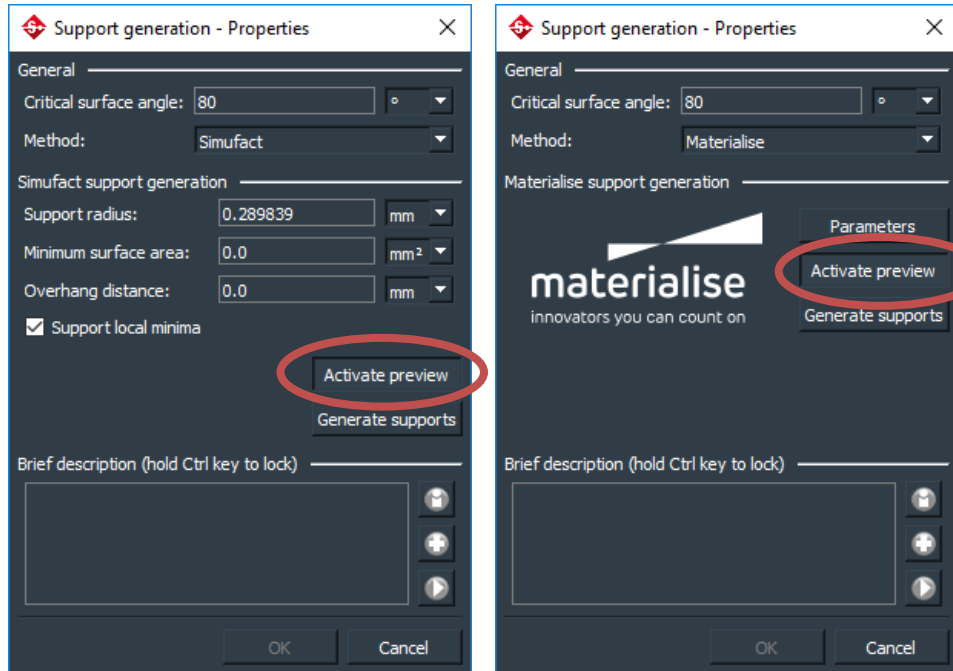

- ◆ **Preview for support surfaces is available** to reduce the time to find the correct support parameters
- ◆ When activating the preview, the surfaces that need to be supported will be shown
- ◆ Preview automatically updates when a value is changed

Further improvements

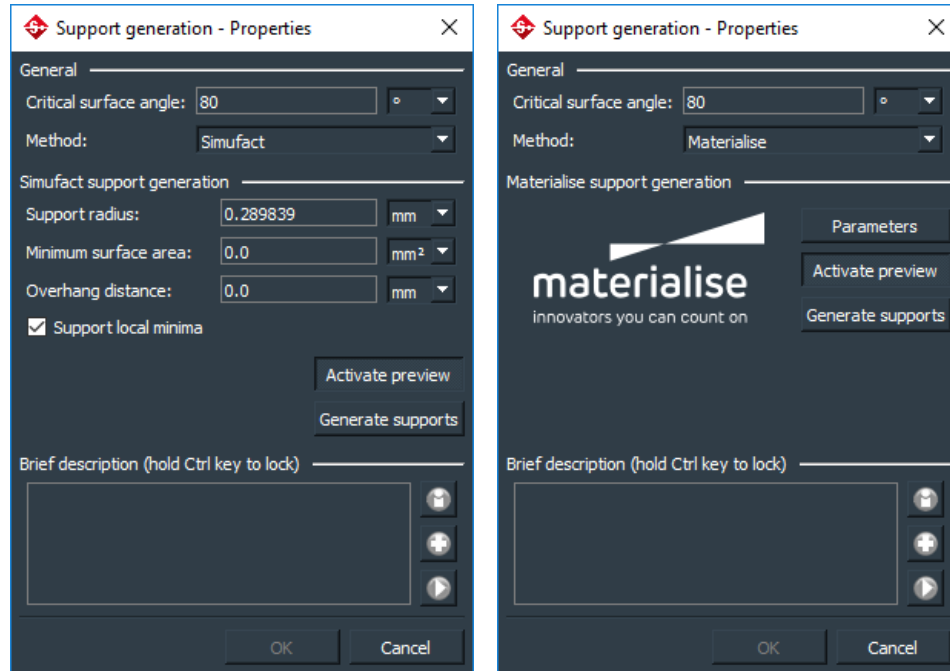

- ◆ Implemented new Materialise API with minor performance improvements
- ◆ When double-clicking on a support group without supports, the support generation dialog will be opened

Further improvements

Front face color

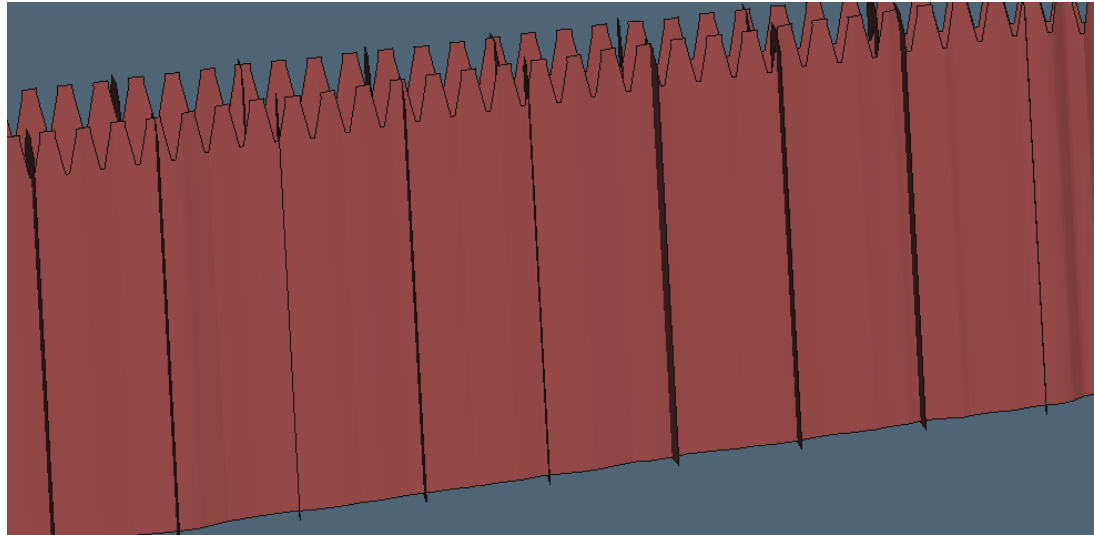

Back face color

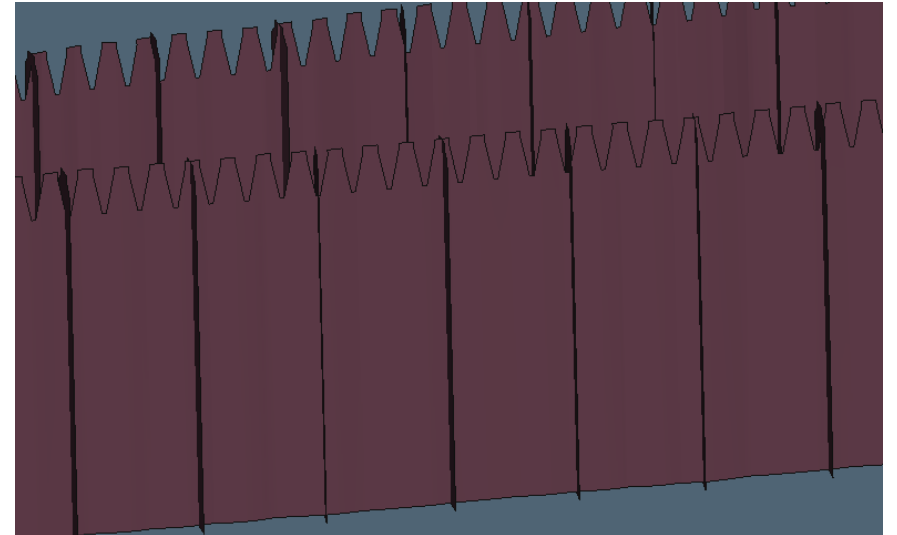

- ◆ **Changed back face color of Materialise and shell supports for better visualization**
- ◆ The back face color was changed from black to a similar color compared to the front face color

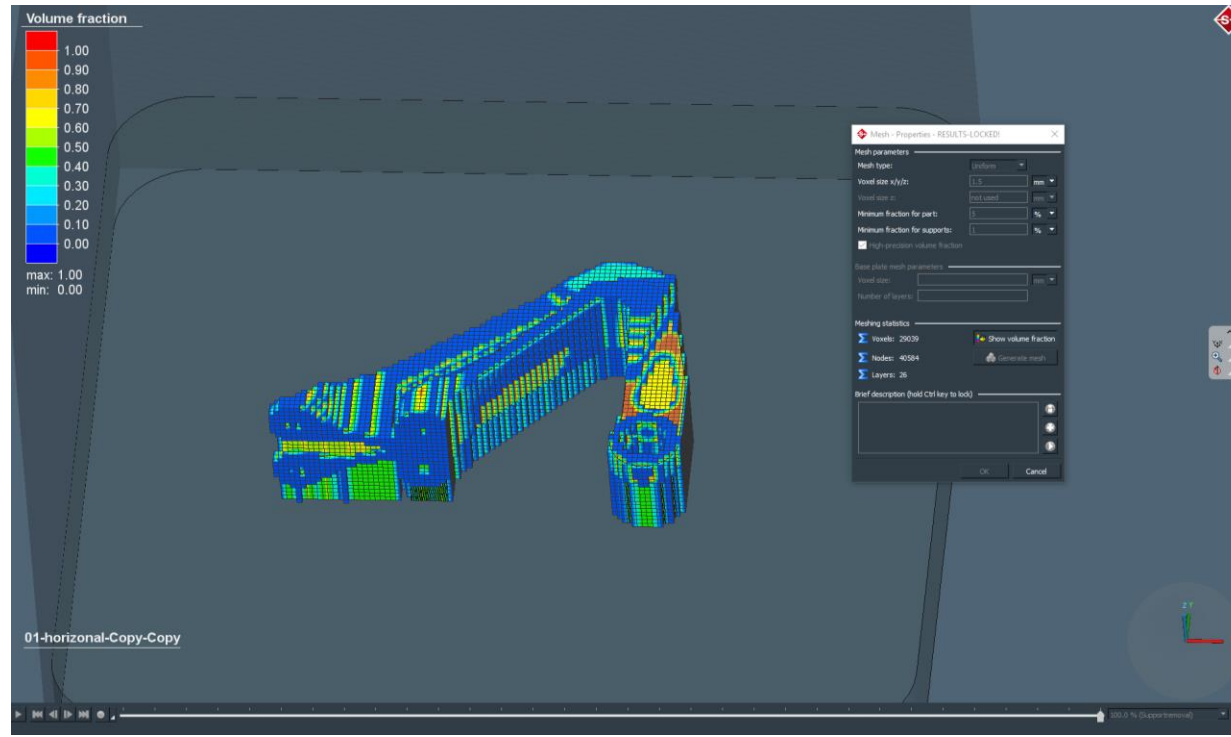

- ◆ Visualization of volume fraction in voxel meshing dialog
- ◆ Allows to check the mesh quality and meshing parameters before starting the simulation

Further improvements

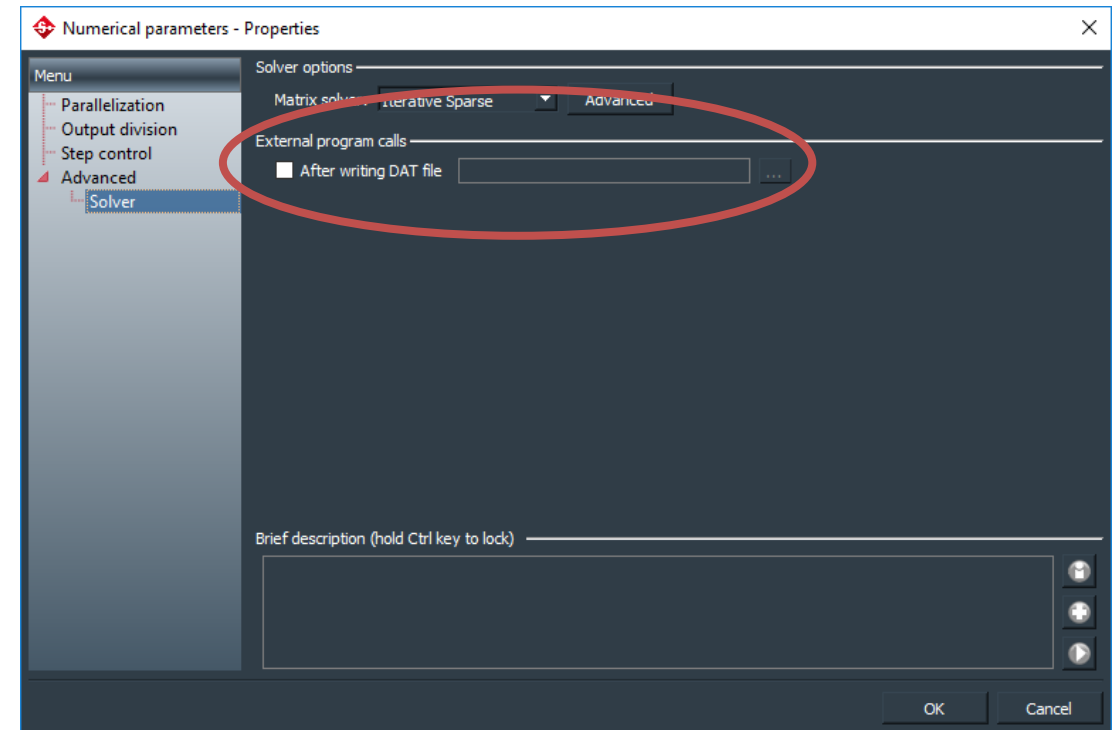
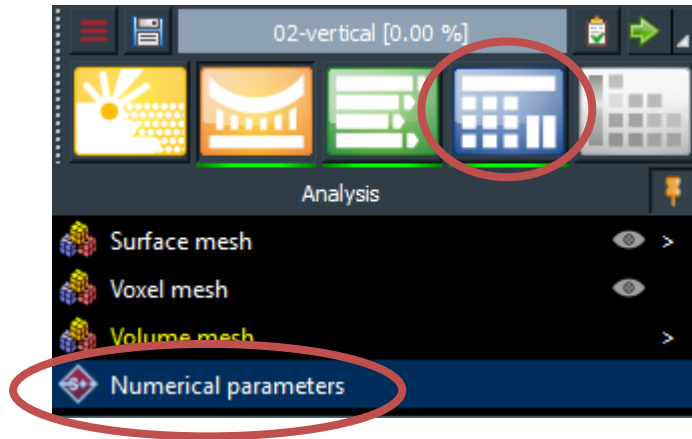

- ◆ **DAT file can be changed automatically after creation** by using an external program or script
- ◆ Program or script can be set in the numerical parameters

Further improvements

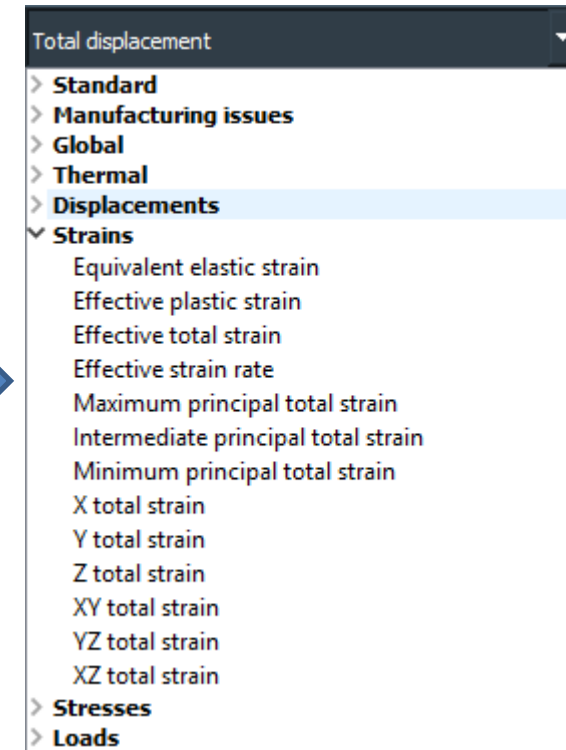
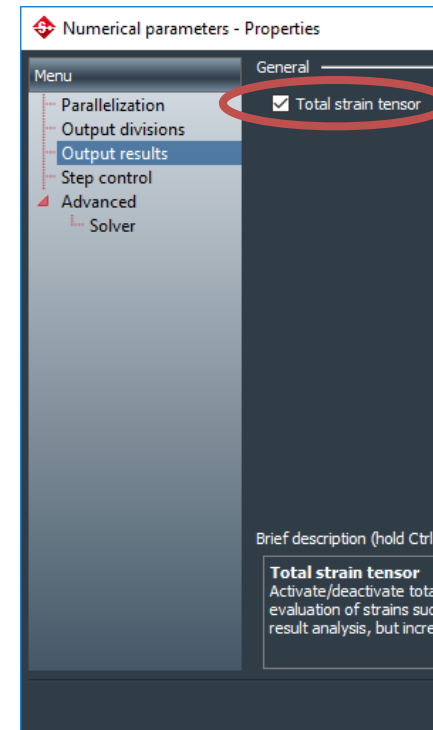
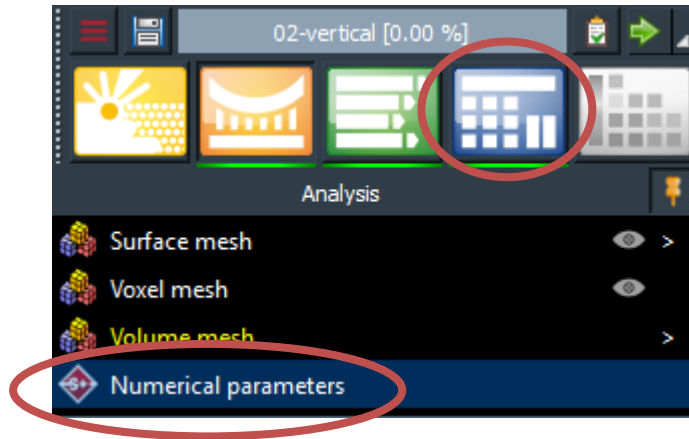

- ◆ Additional strain result values are available during post processing
- ◆ Added optional output of total strain tensor to numerical parameters
- ◆ Default option can be controlled via INI file

Further improvements

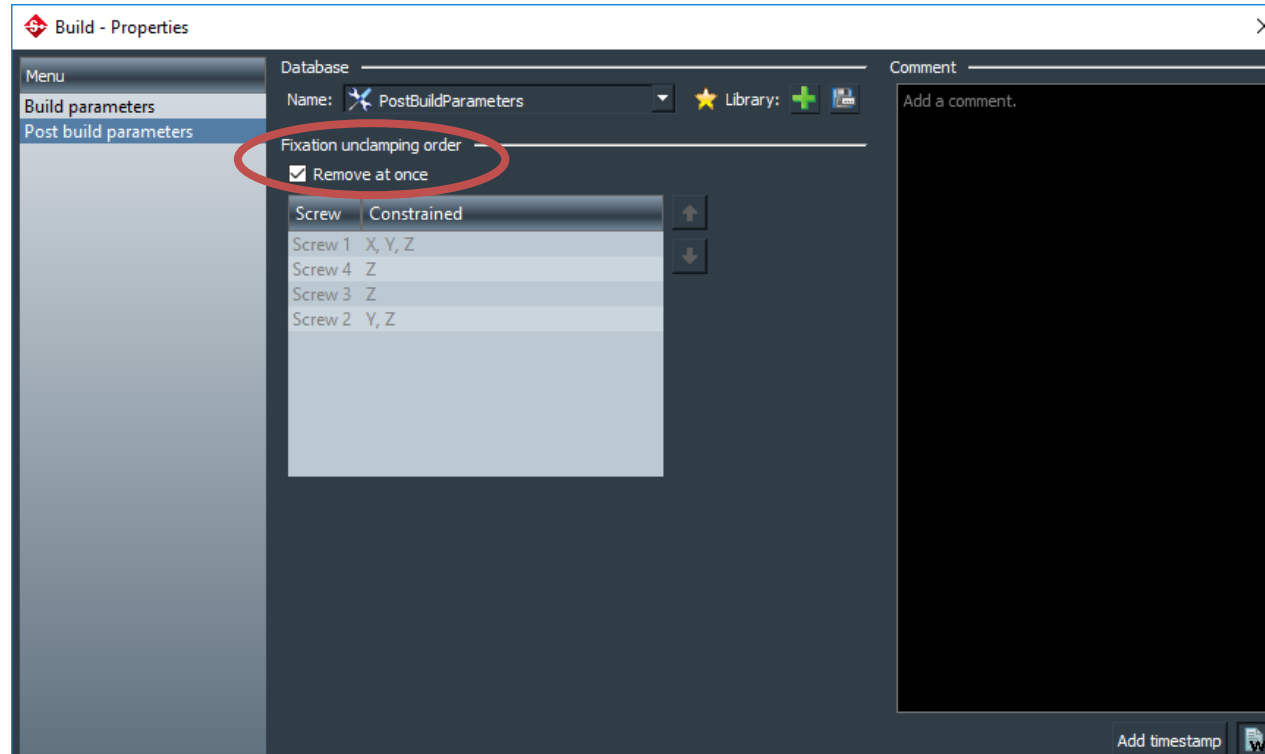

- ◆ Allow to remove all fixations in a single time step
- ◆ Capture the real effects more precisely

Further improvements

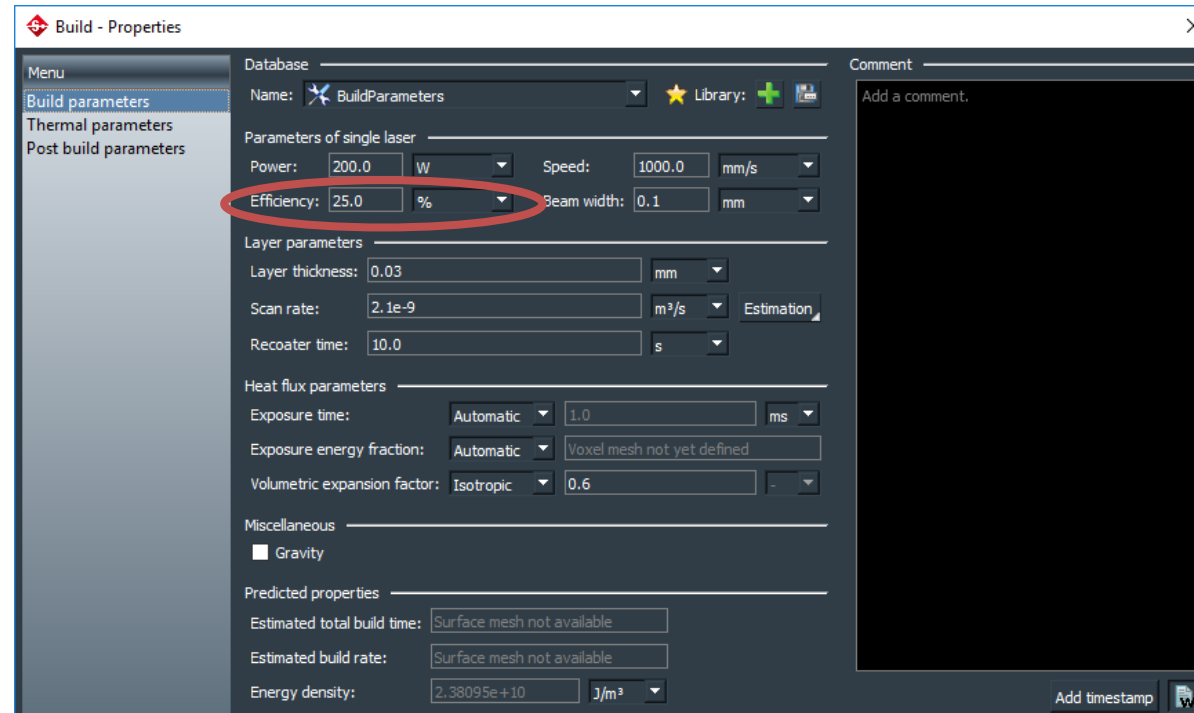

◆ Changed default efficiency for thermal and thermomechanical simulations to a more suitable and realistic value

◆ Old value was 50%, new value is 25%

Further improvements

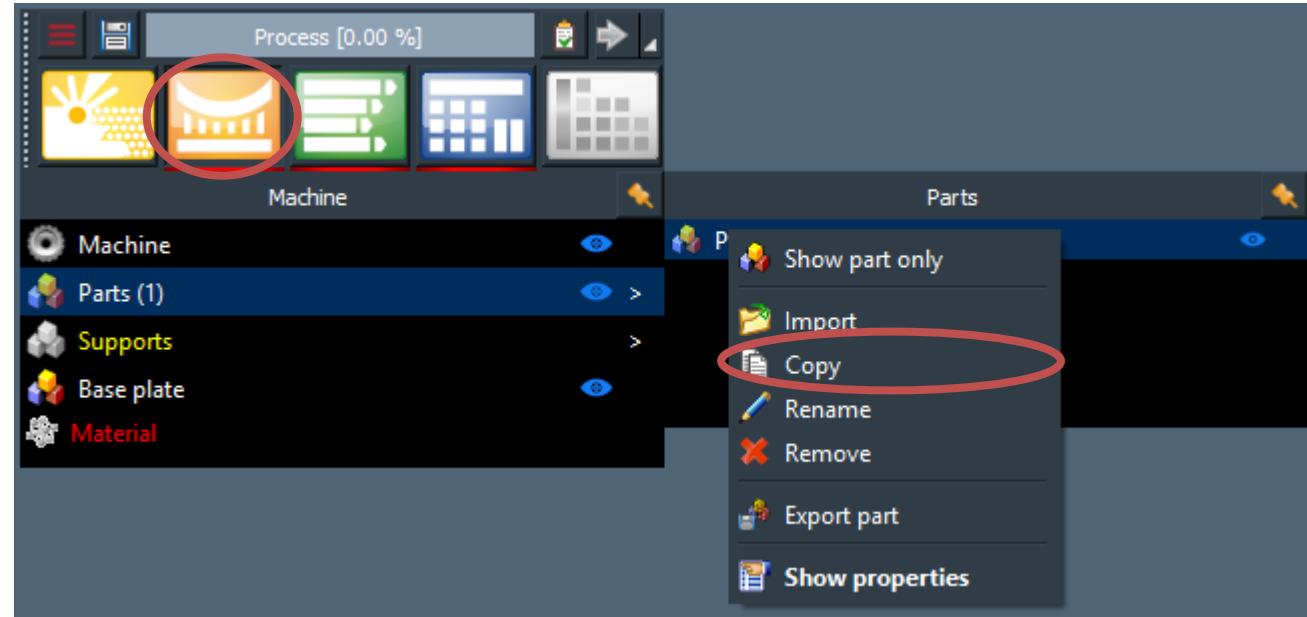

- ◆ **Avoid the need to import identical parts multiple times by using the new **copy part** function**
- ◆ Copied parts will be shifted into positive X direction but only once

Further improvements

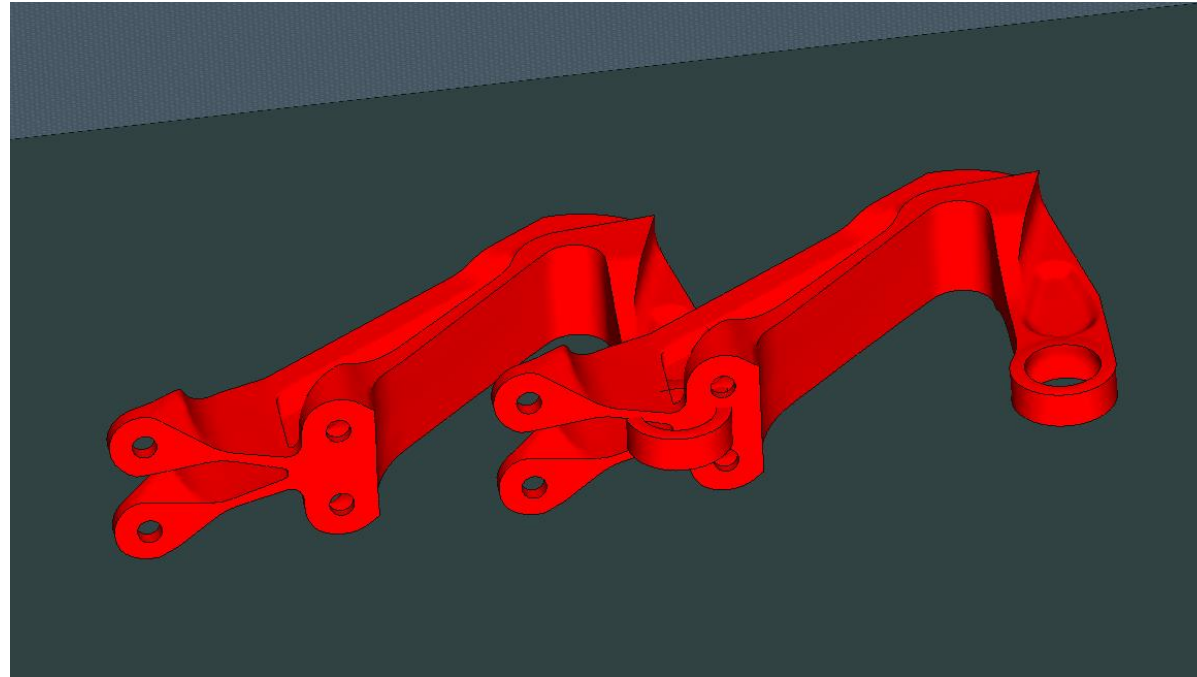

- ◆ Support the user by finding errors in the model setup by highlighting intersections between part/support and part/base plate

Further improvements

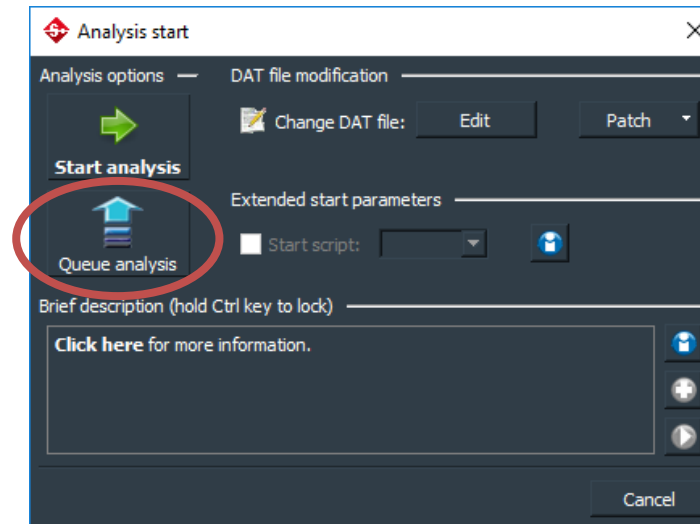
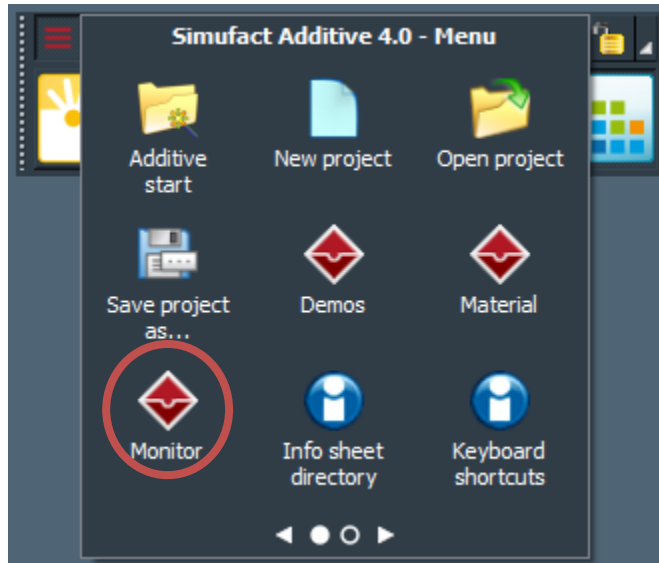

- ◆ **Allow to queue jobs using Simufact Monitor**
- ◆ Simufact Monitor is included in the setup and can be opened using the menu
- ◆ When starting a simulation, the job can be sent to Simufact Monitor and will be added to the queue

Further improvements

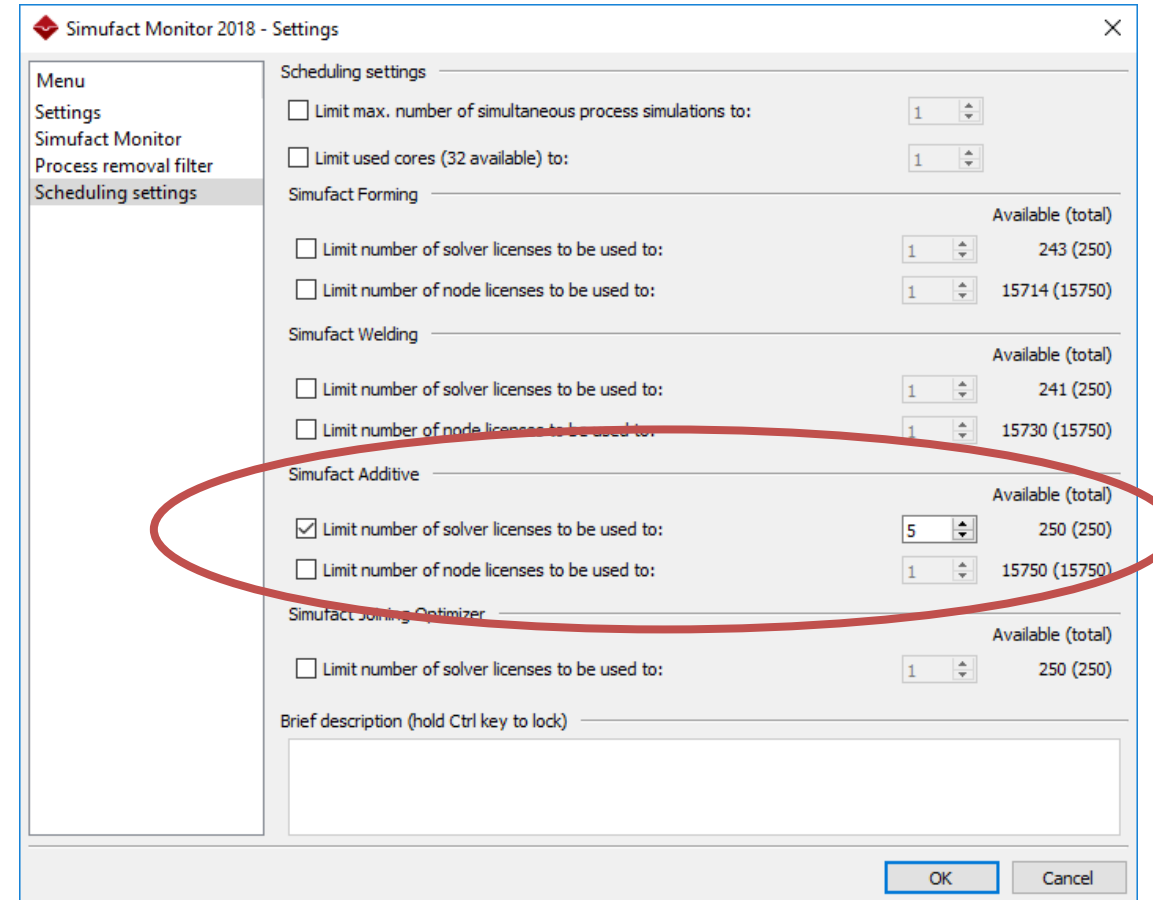
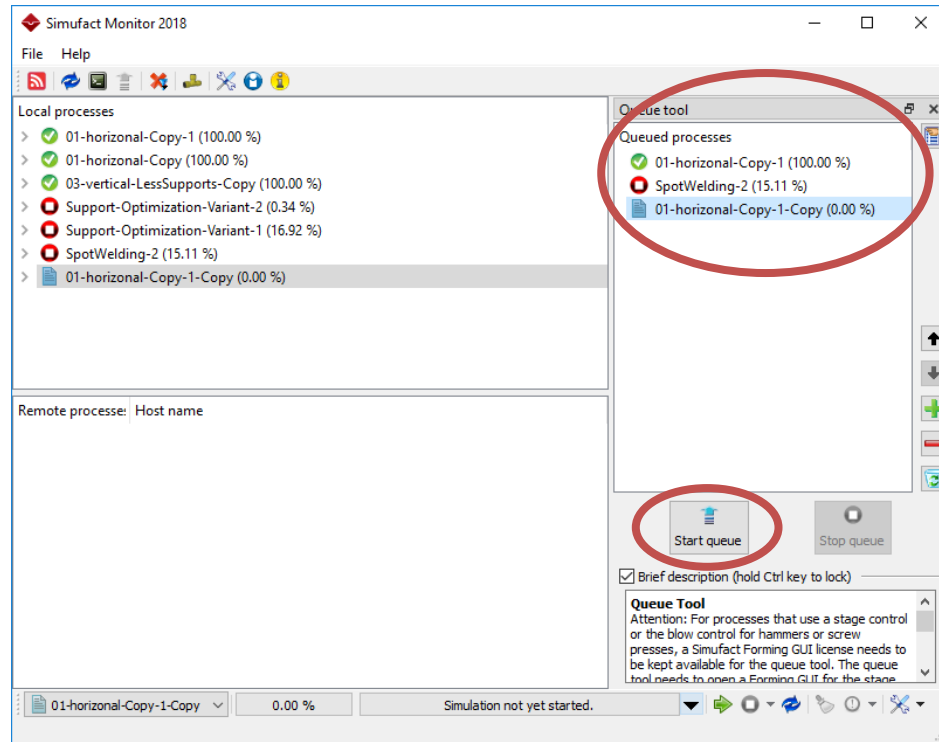

- ◆ The queue can be started in Simufact Monitor
- ◆ Settings for license scheduling allow optimal usage of available licenses and hardware

Further improvements

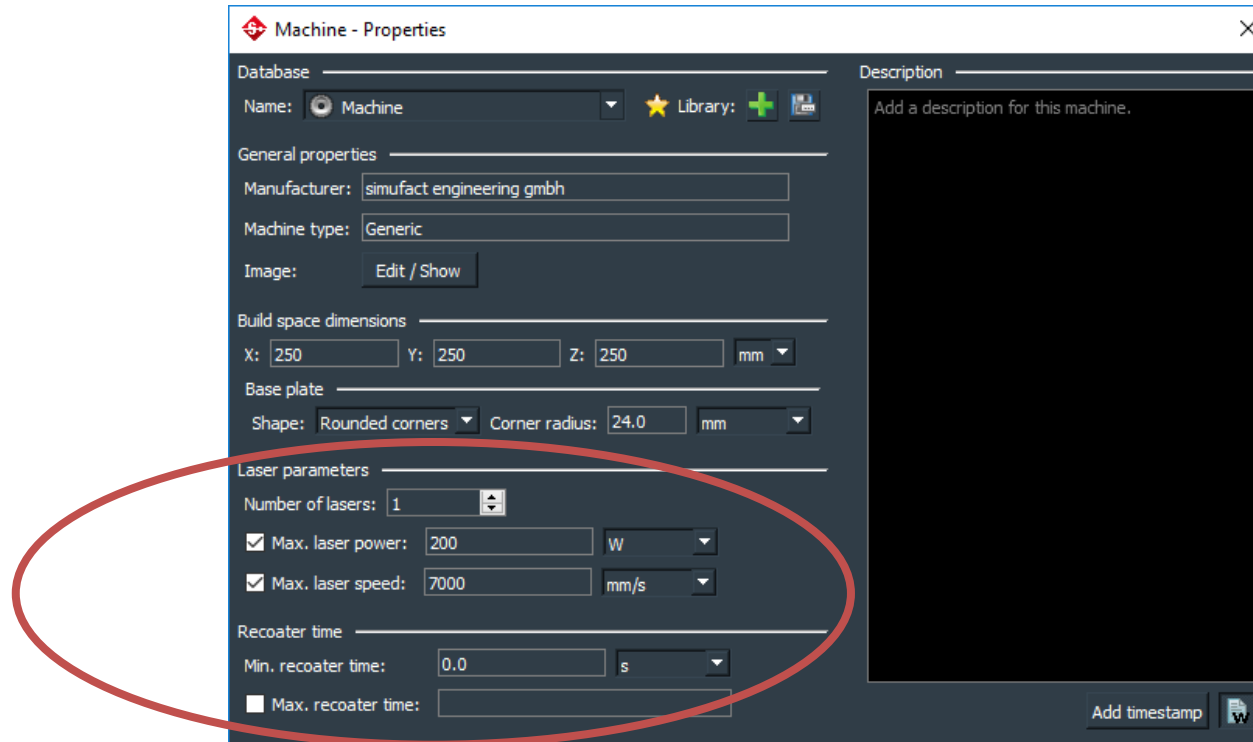

- ◆ **Capture the effect of multi-laser machines on the build time** for thermal and thermomechanical simulations by storing additional information like number of lasers
- ◆ Added laser parameters and recoater times to machine
- ◆ Information will be used to validate settings in thermal and thermomechanical build stage
- ◆ Extended machine database

Further improvements

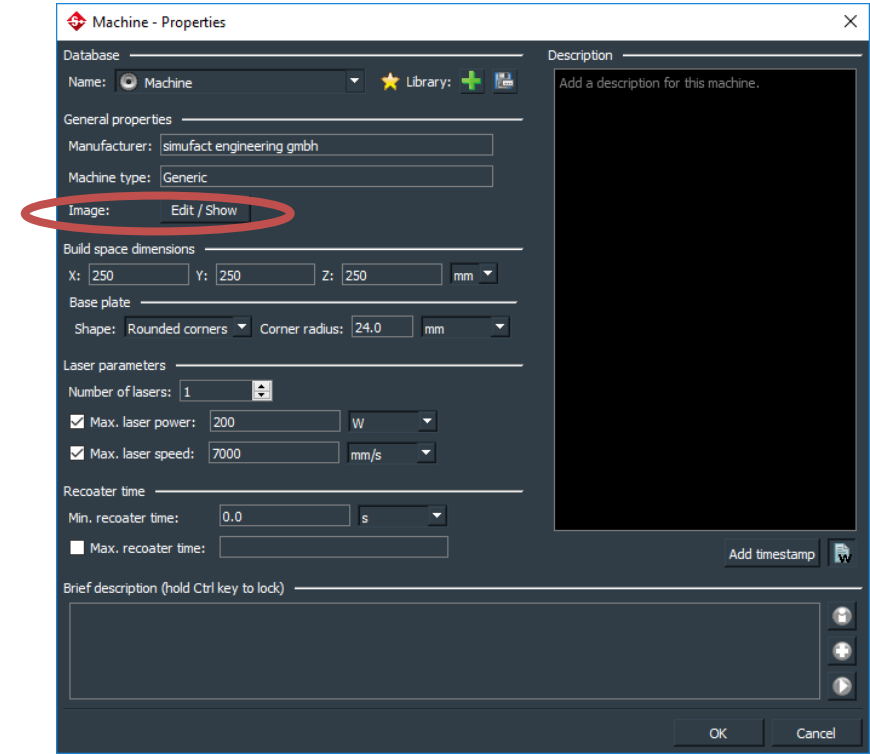
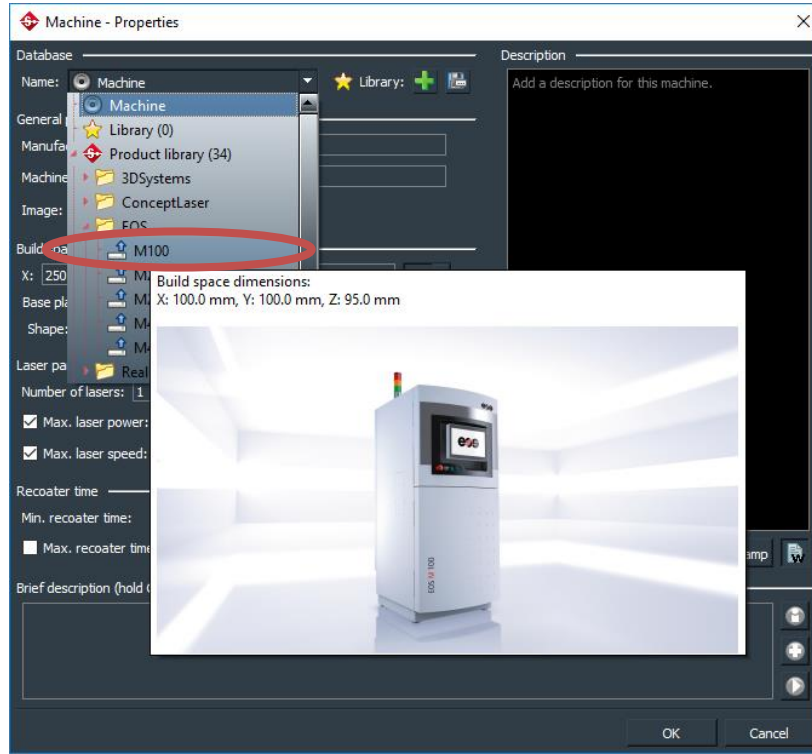

- ◆ Machine database can now contain and show images
- ◆ Images and the build space dimension will be shown as tooltip when hovering the mouse briefly on the database entry
- ◆ Images can be stored or deleted in the machine dialog

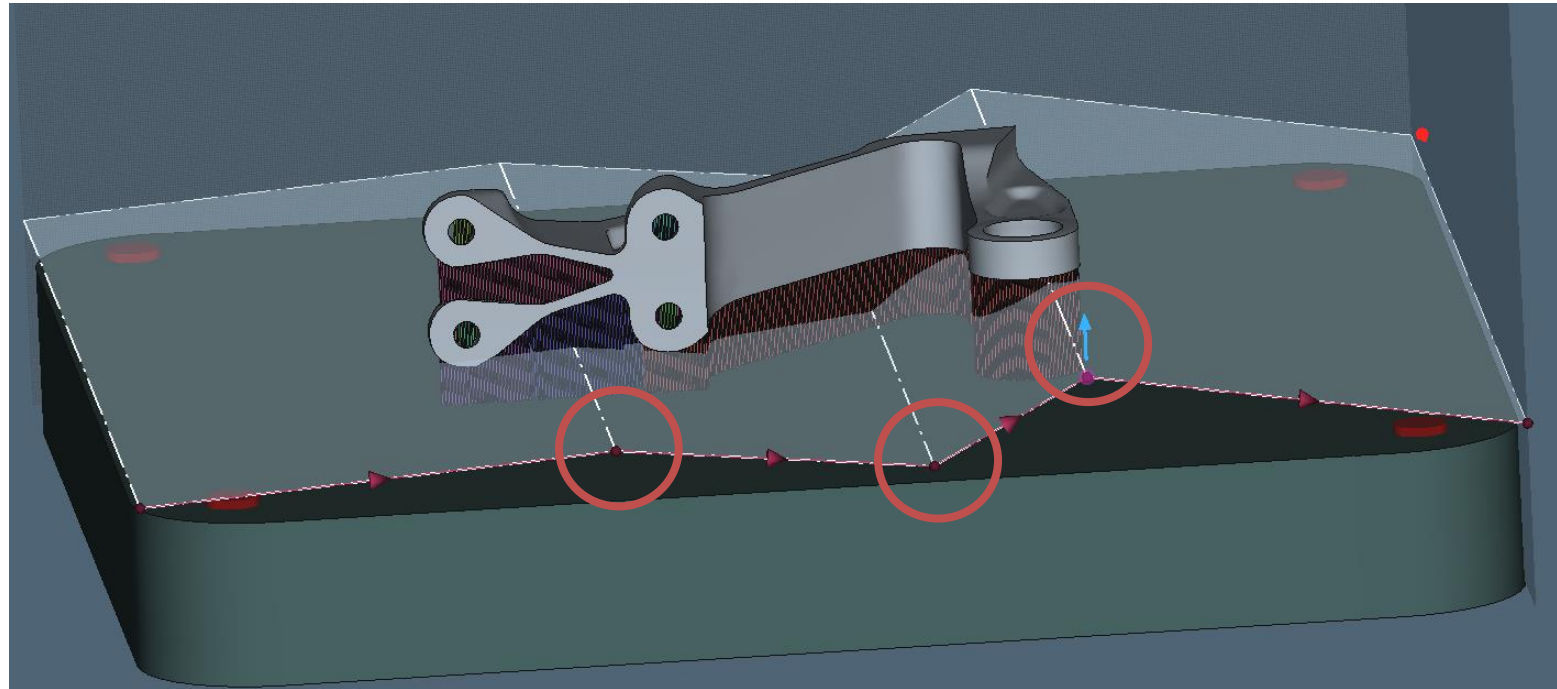

- ◆ **Easier and faster definition of cutting stages by view interaction**
- ◆ The cutting stage can be completely defined in the view using known GUI elements
- ◆ Also the cutting height table can be defined in the view by adding or removing points, setting the height of points etc.

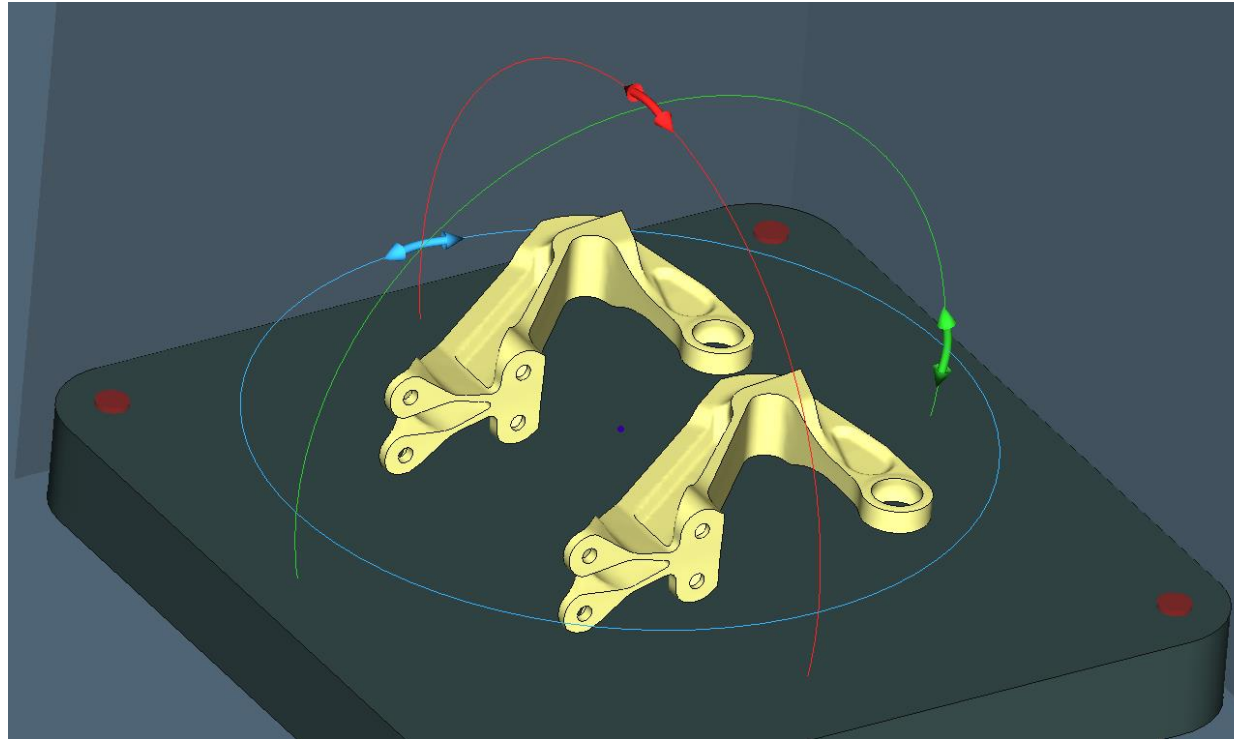

- ◆ **Easier and faster positioning by multiple selection**
- ◆ Multiple bodies can be selected by holding the CTRL key and clicking with the left mouse button during positioning mode
- ◆ All translations and rotations will be applied to the selected bodies

Further improvements

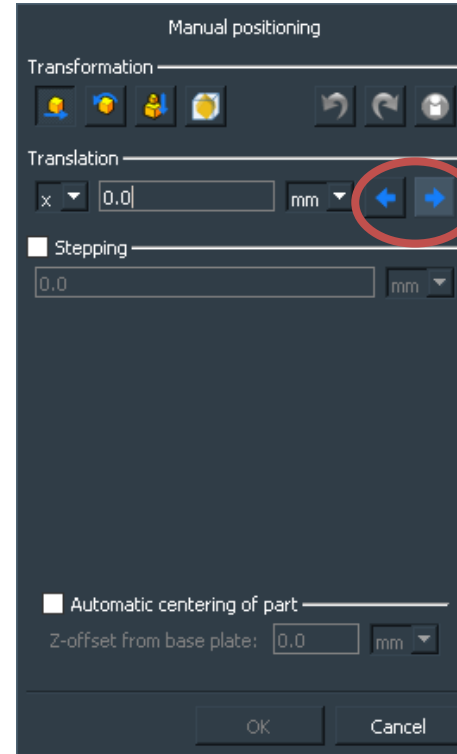
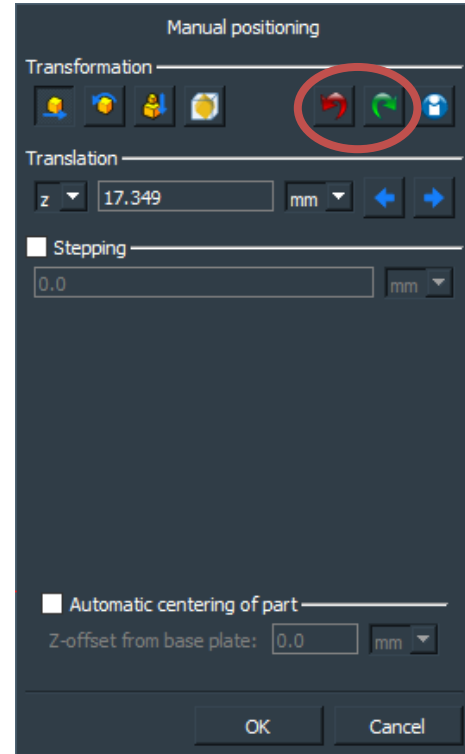

- ◆ **More flexibility by using „Redo“ during positioning mode**
- ◆ **Compare different positions easy and fast**
- ◆ **The currently selected button is highlighted when clicking in the input field to identify which direction will be used when hitting enter**

Further improvements

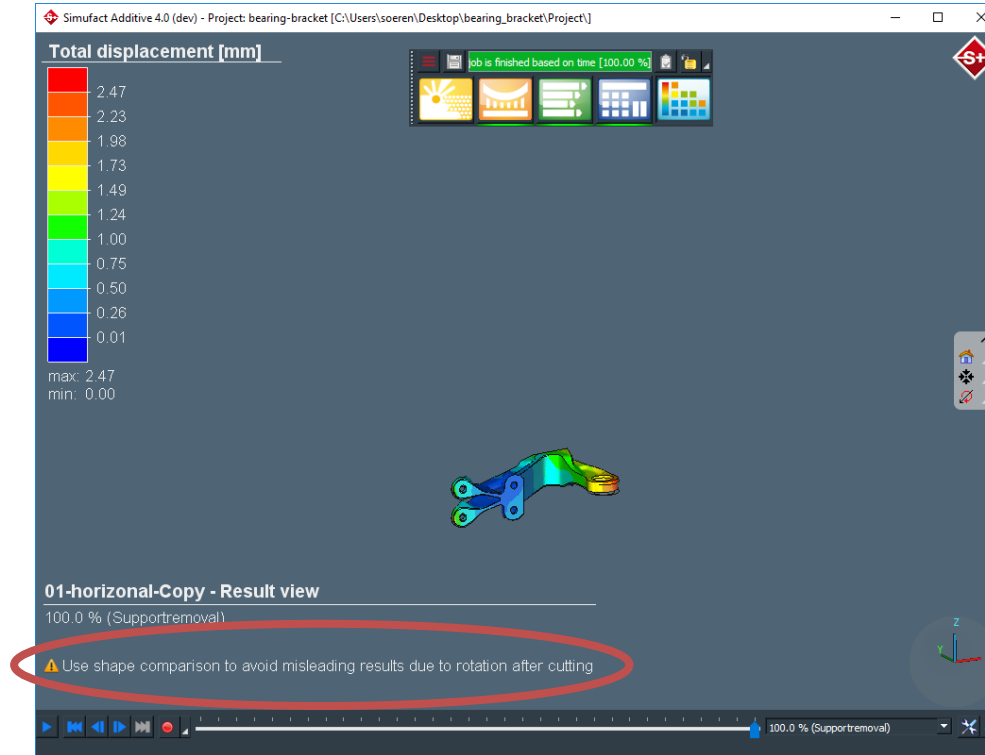

- ◆ **Added warning message for result value displacements** if the currently shown time step is **after cutting**
- ◆ Warning informs the user that displacement results after cutting might be misleading due to large displacements and rotations of the part (rigid body modes)
- ◆ Use shape comparison to avoid these effects

Further improvements

- ◆ **Geometries** can be **imported** even if they are **outside the machine space** or **do not fit in the machine space** to avoid unusual workflows
- ◆ Red machine walls indicate that at least one geometry is not inside the machine space

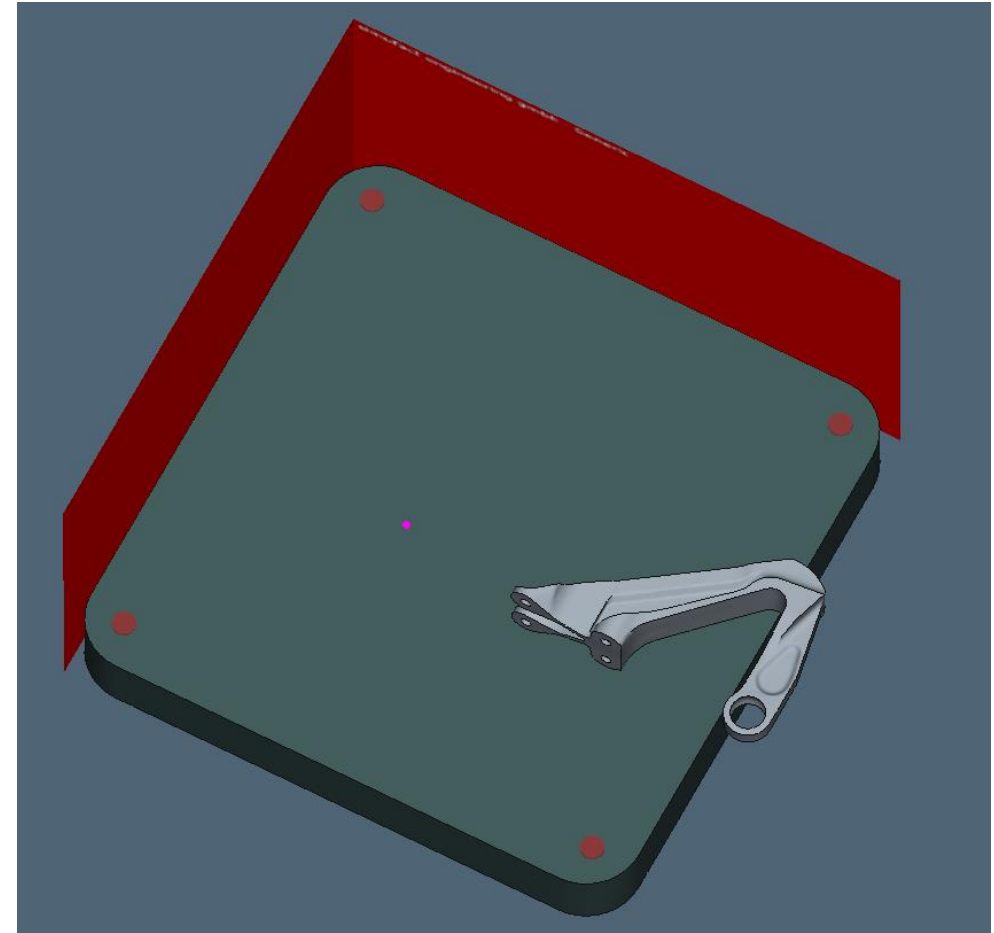

Further improvements

- ◆ **Error handling** was added to **orientation assistant** if a criterion could not be calculated (to avoid misinterpretation)

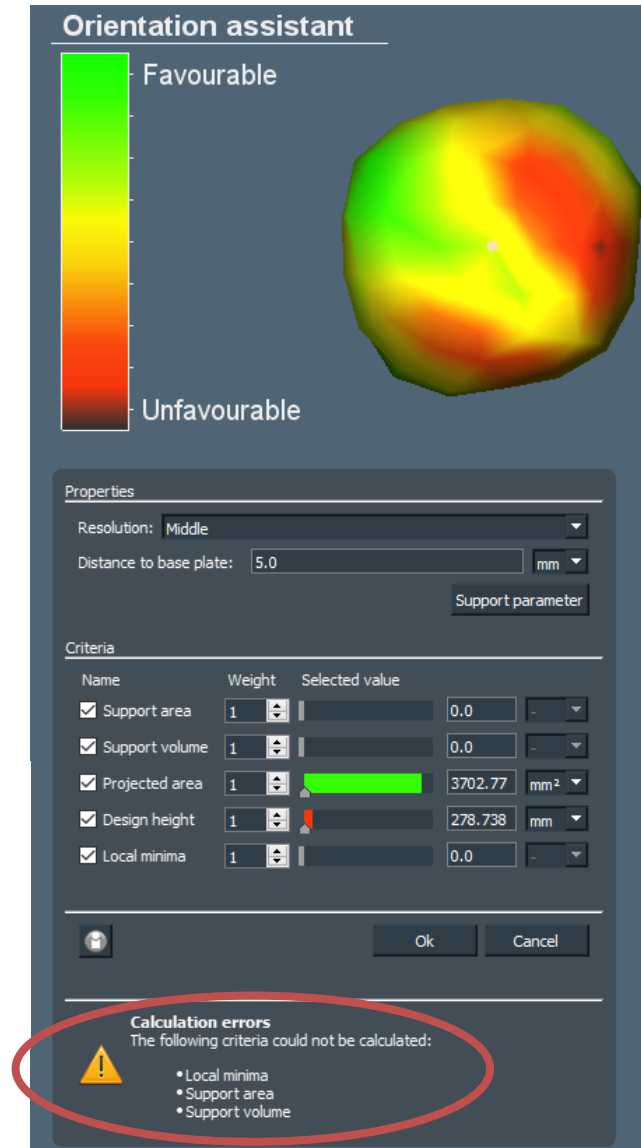

Further improvements

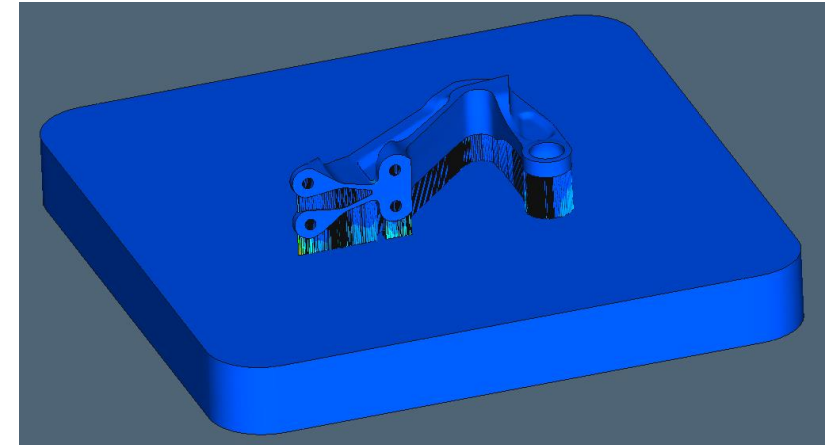
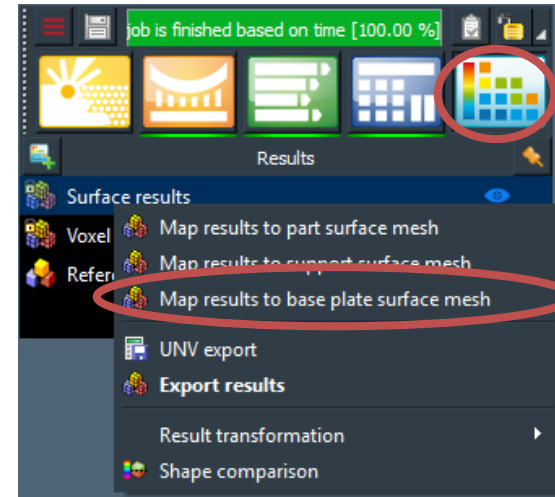
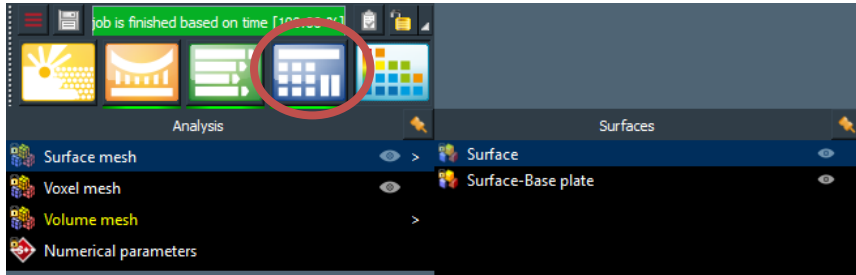

- ◆ **Surface results for base plate can be mapped**
- ◆ This allows a smooth and good-looking view on the results
- ◆ Base plate can be surface-meshed

Further improvements

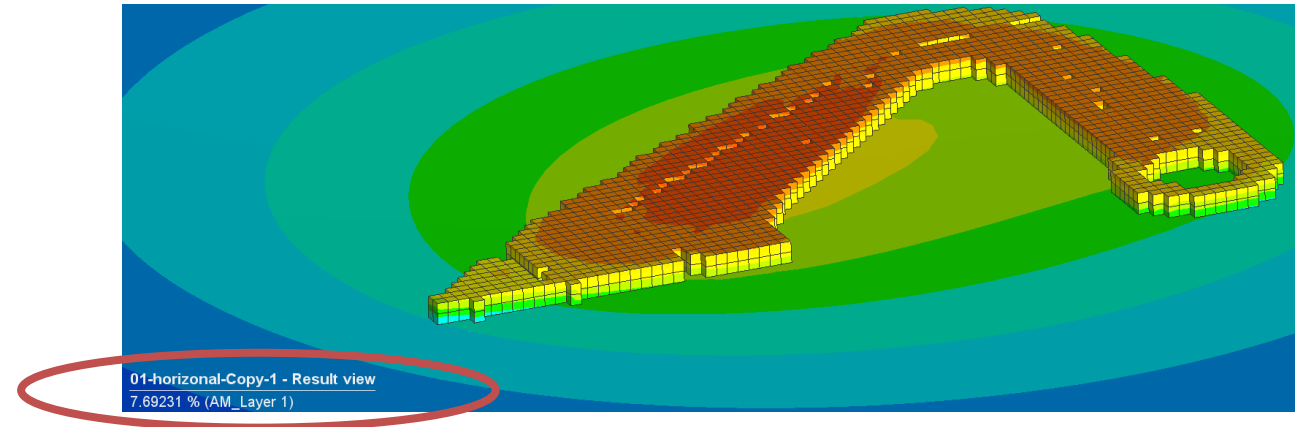
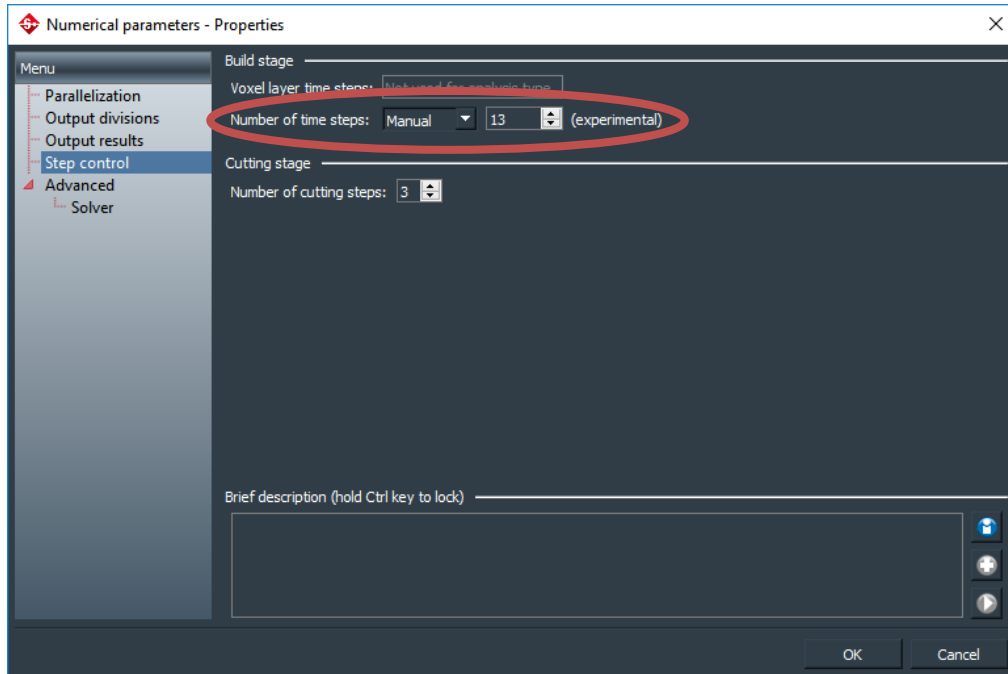

- ◆ Reduction of simulation time by activation of multiple layers per time step
- ◆ Default is one voxel layer per time step
- ◆ Supported in mechanical, thermal and thermomechanical simulations
- ◆ **This feature is experimental. Thus it cannot be guaranteed that every possible constellation of options is available and works.**

Further improvements

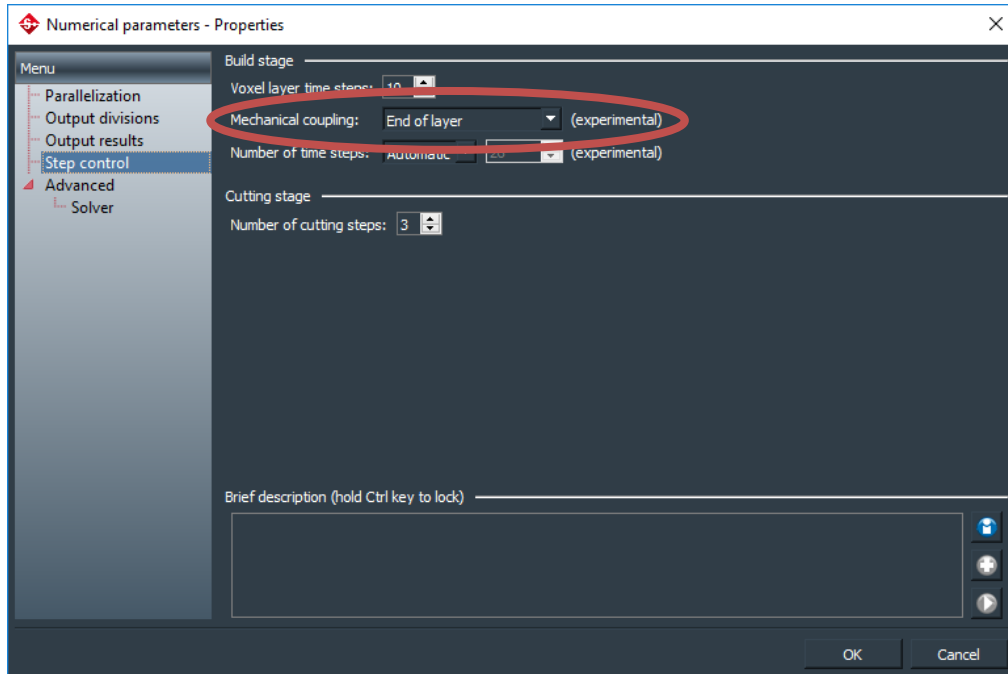

- ◆ Reduction of simulation time by performing mechanical coupling steps only at the end of the layer
- ◆ Default is performing 4 coupling steps per layer, new option reduces to 1 coupling step
- ◆ Supported only in thermomechanical simulations
- ◆ **This feature is experimental. Thus it cannot be guaranteed that every possible constellation of options is available and works.**

Further improvements

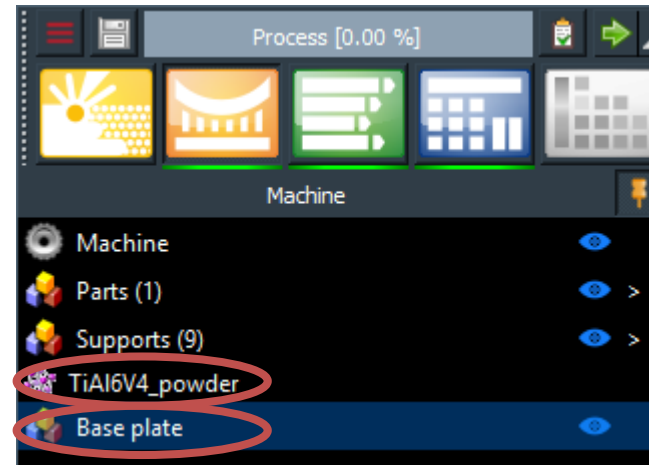

- ◆ **Improved order within machine widget**
- ◆ The new order shows that the material in the machine widget is not applied to the base plate
- ◆ Base plate material is defined in the base plate properties dialog
- ◆ Also the base plate is not necessarily needed for mechanical simulations

Further improvements

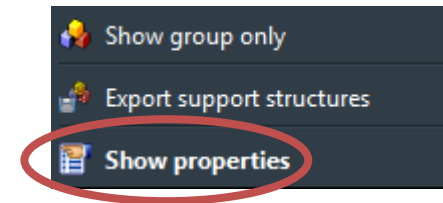
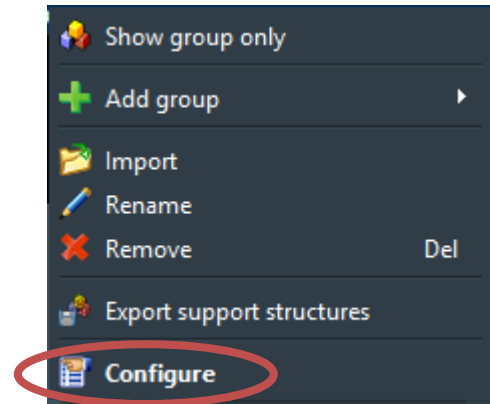

- ◆ Distinguish between „Show properties“ and „Configure“ to clearly show what can be done in the corresponding dialog
- ◆ „Configure“ for unlocked processes
- ◆ „Show properties“ for locked processes

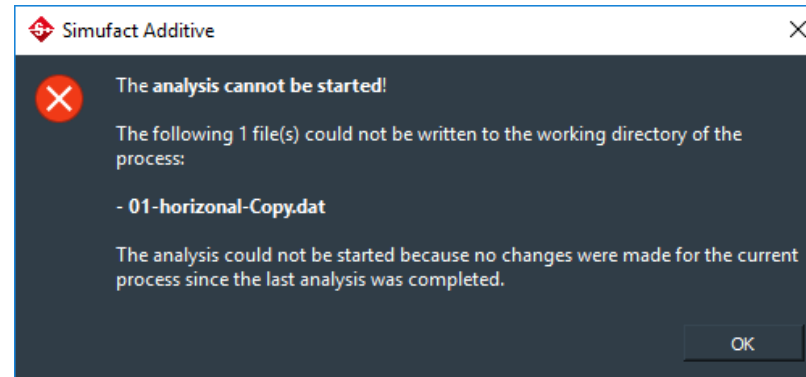

- ◆ **When a process is unlocked and started again without any changes, an error will be shown** stating that no changes were made and the simulation will not be started

Further improvements

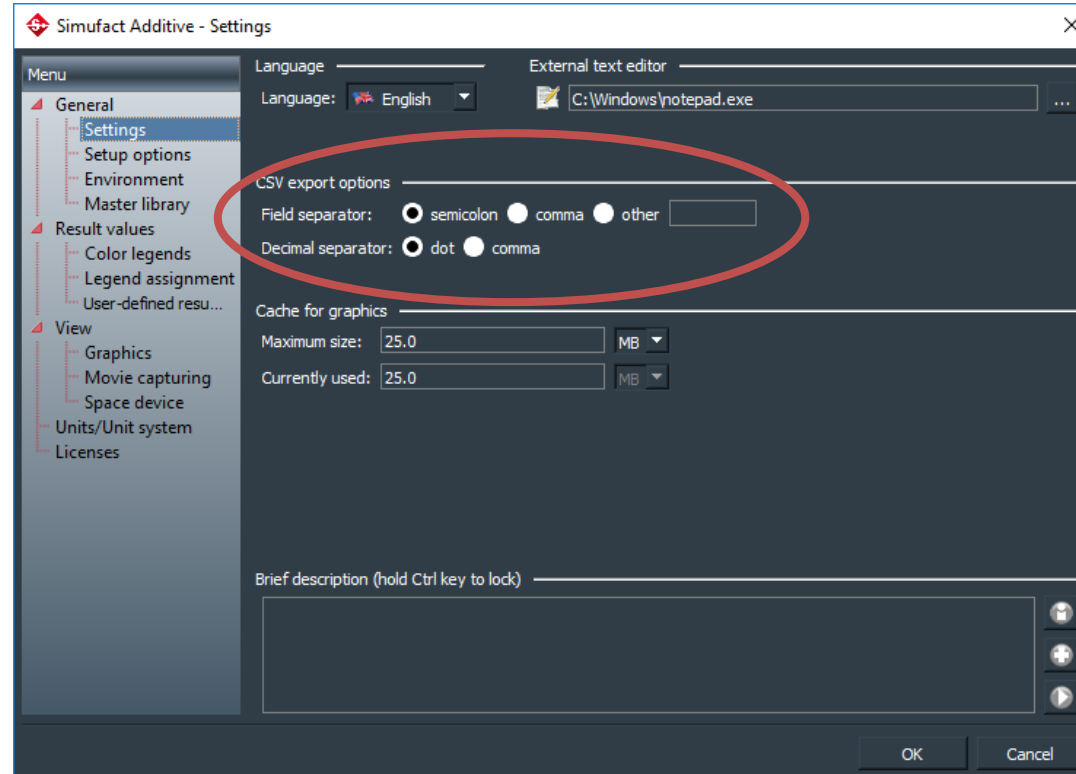

- ◆ Reduces the need to configure CSV options for every single export
- ◆ Added global options for CSV export as well as clipboard export

Further improvements

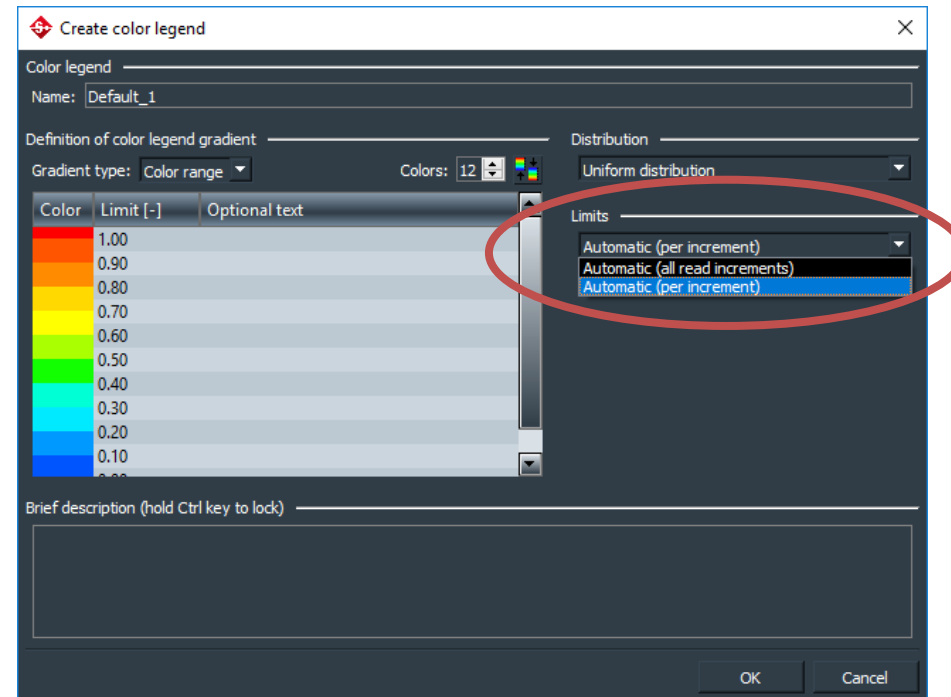

- ◆ The limit of user-defined color legends can be set during definition
- ◆ Avoid the need to set the limits every time manually in the result view

Further improvements

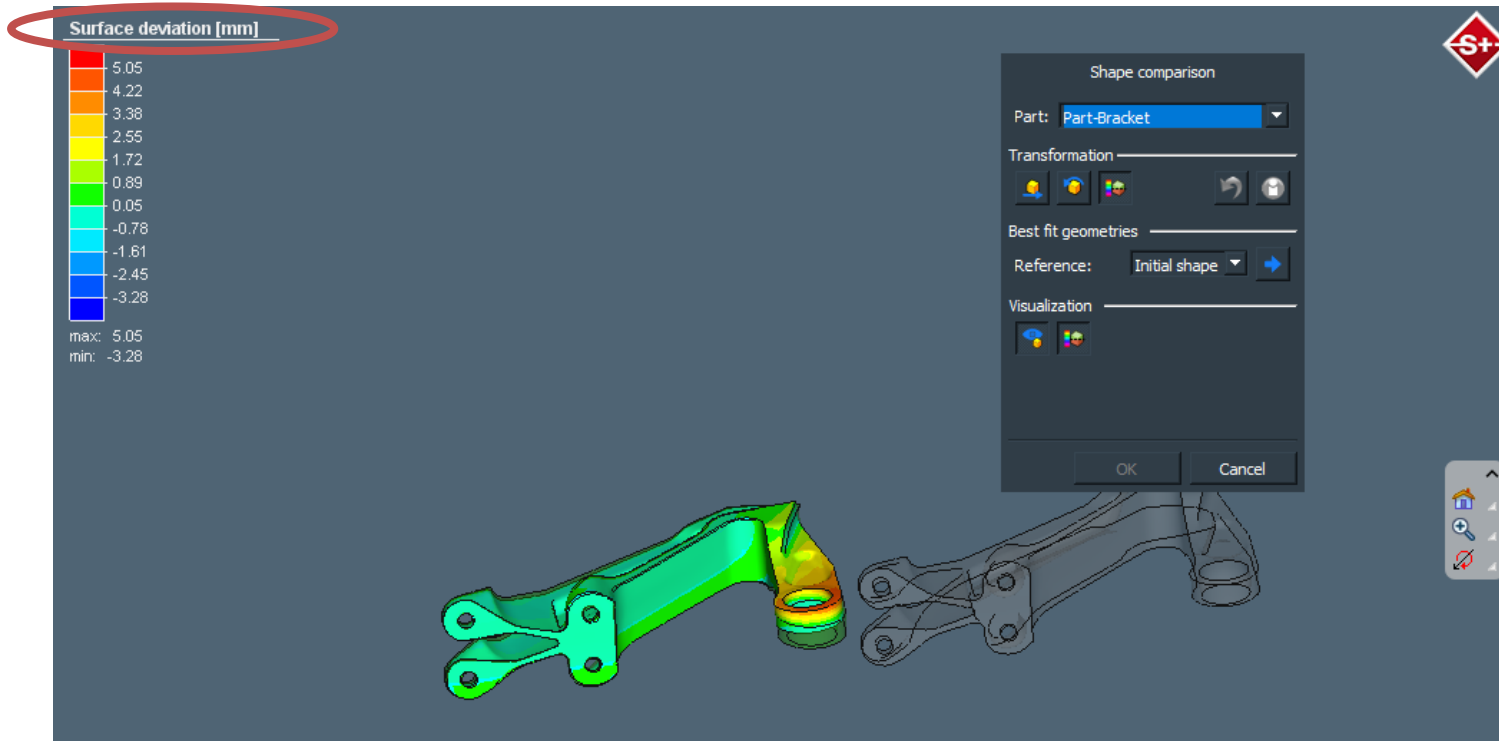

- ◆ **Renamed** result value „shape comparison“ to „surface deviation“ as it is the same result value
- ◆ This makes it more clear what is actually calculated
- ◆ Surface deviation is now calculated based on nodal distances and not on element distances anymore. This method shows more reasonable results.

Further improvements

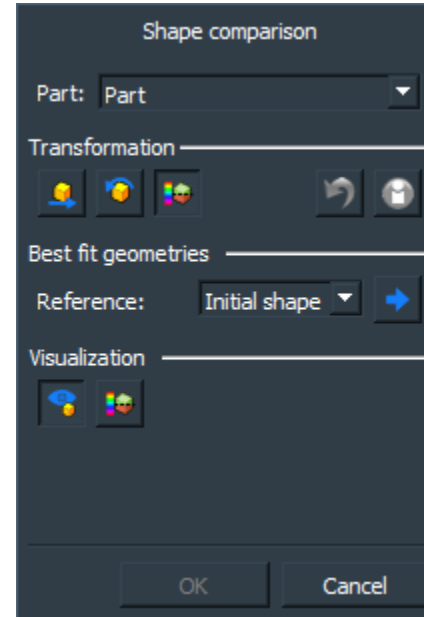

- ◆ **Improved design of shape comparison dialog** to allow faster switching of part to be positioned
- ◆ Clearer naming of GUI elements so that support of multiple parts can be seen directly

Further improvements

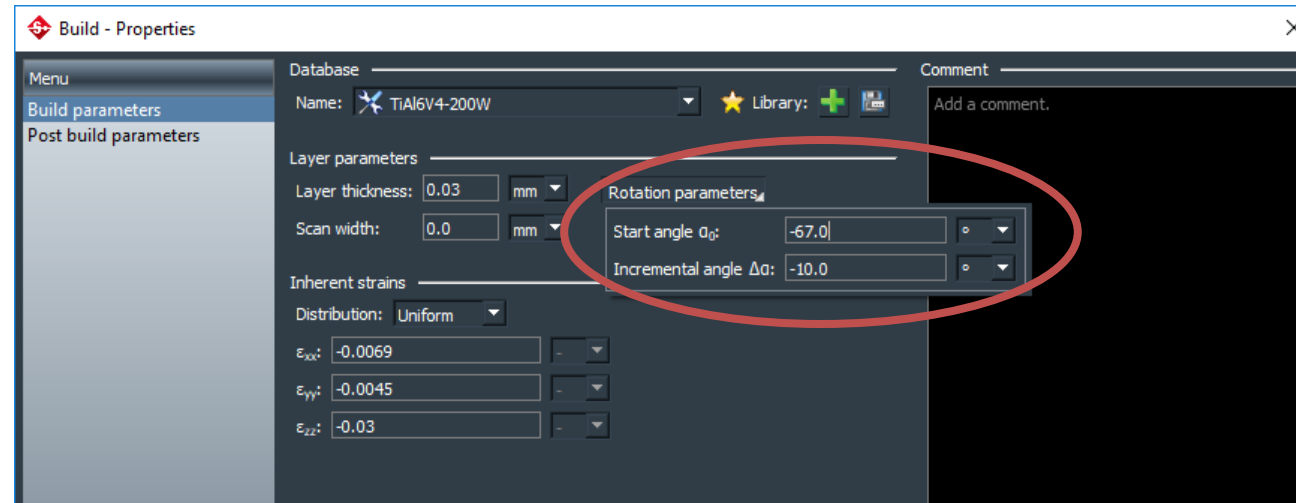

- ◆ Allow negative input for start angle and incremental angle for mechanical simulations

Further improvements

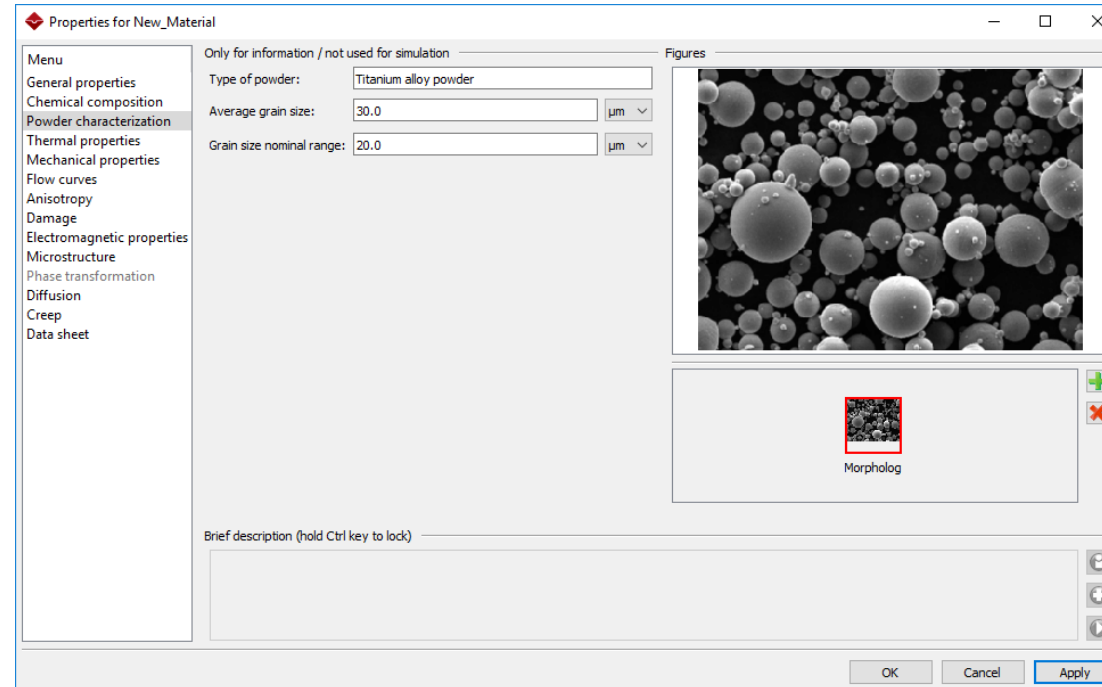

- ◆ Added page in Simufact Material to document powder properties including upload of pictures

Further improvements

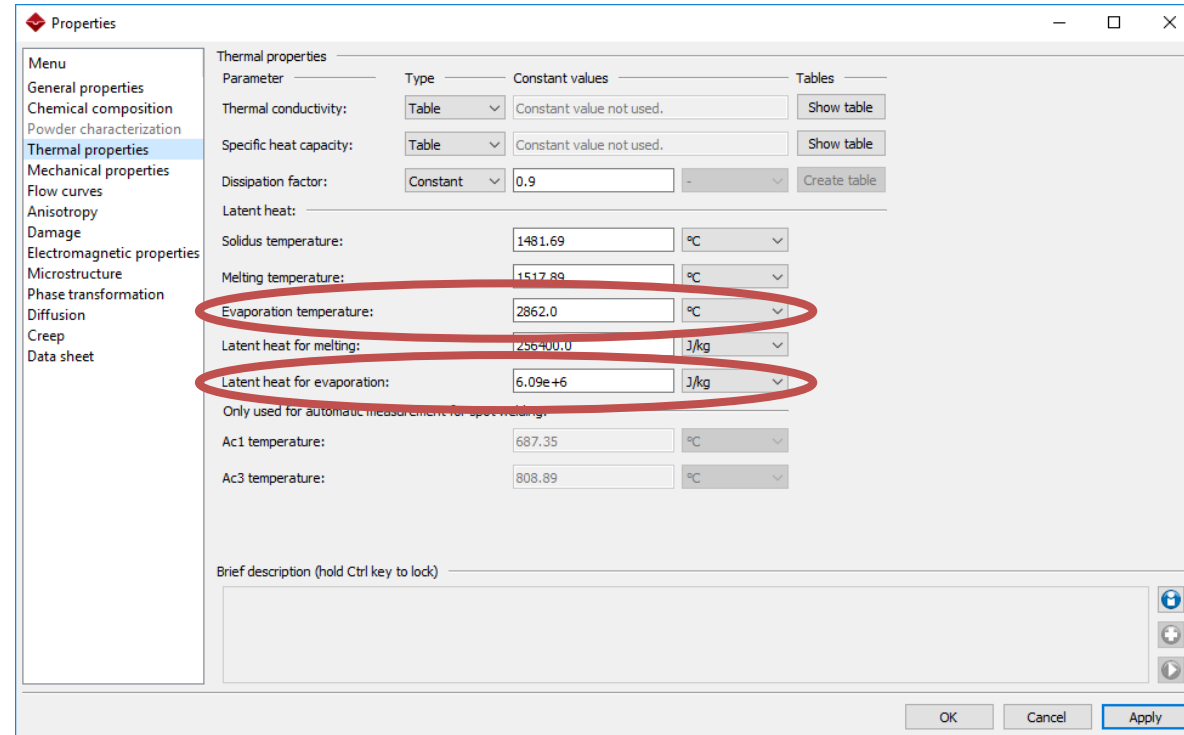

- ◆ Added **additional latent heat for evaporation** to cover the physical effects and prevent an overheating in thermal and thermomechanical simulations

Further improvements

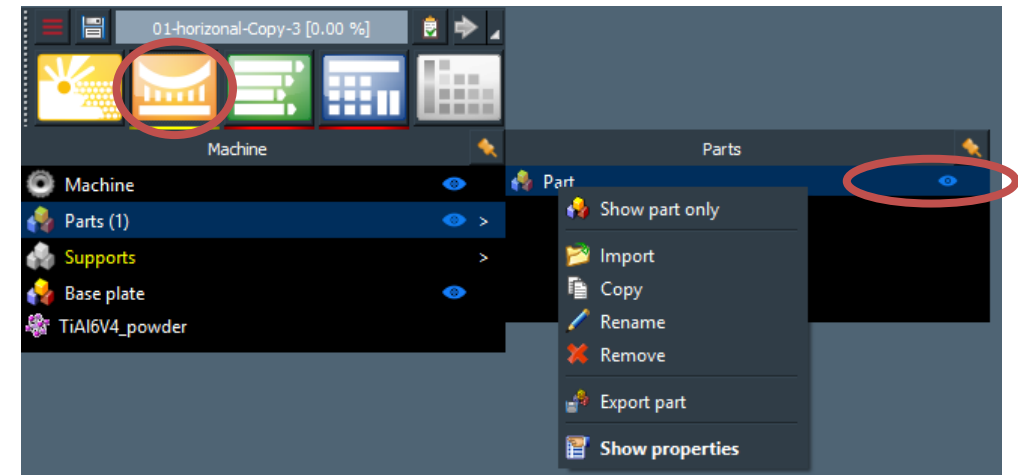
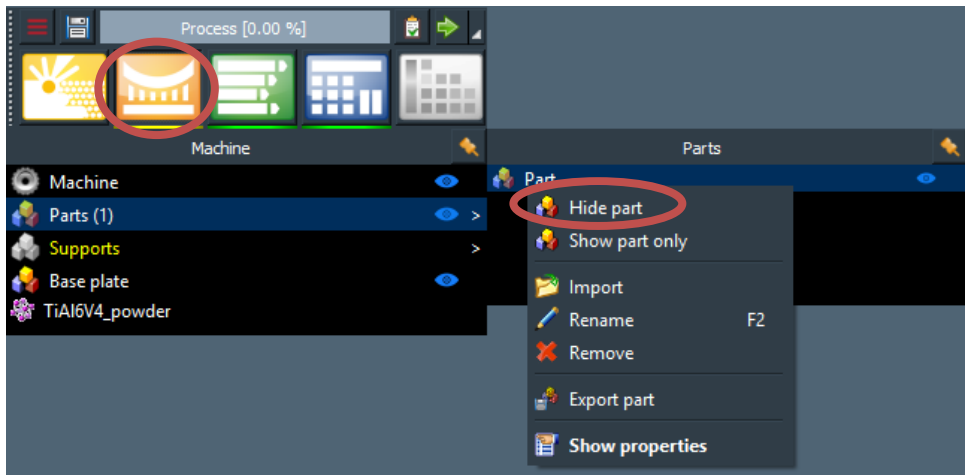

- ◆ **Removed duplicate functions for showing and hiding geometries** from context menu in main widget
- ◆ Geometries can only be shown and hidden using the blue eye icon

Further improvements

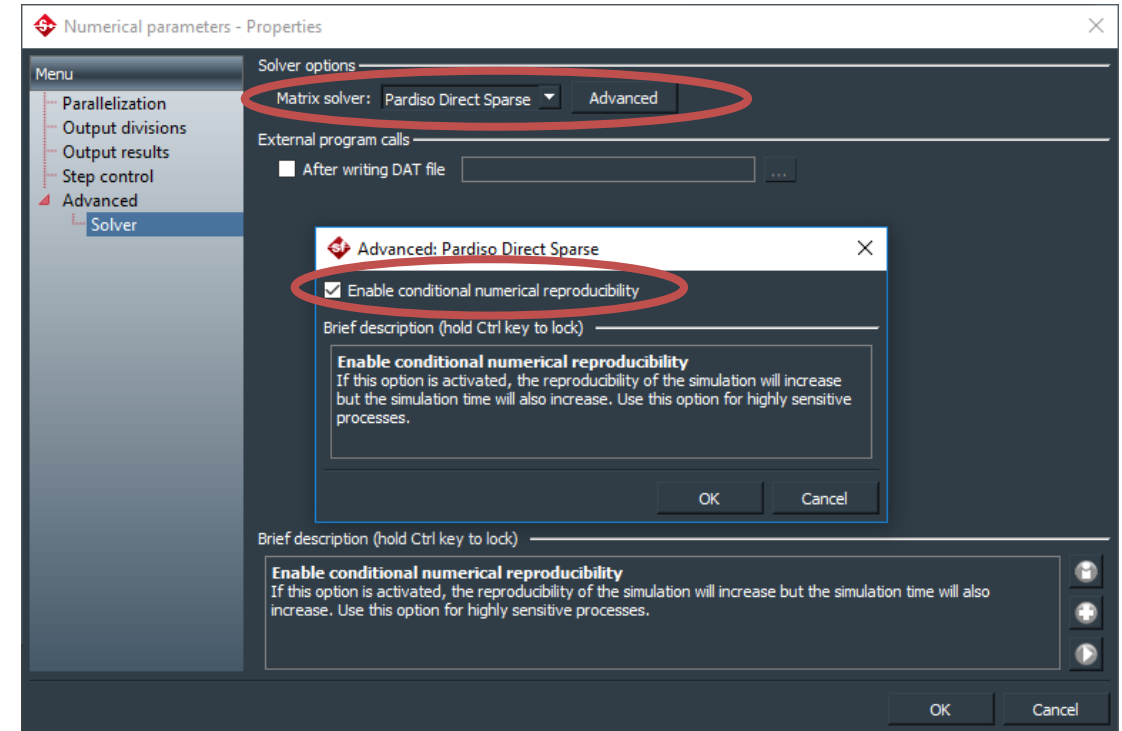
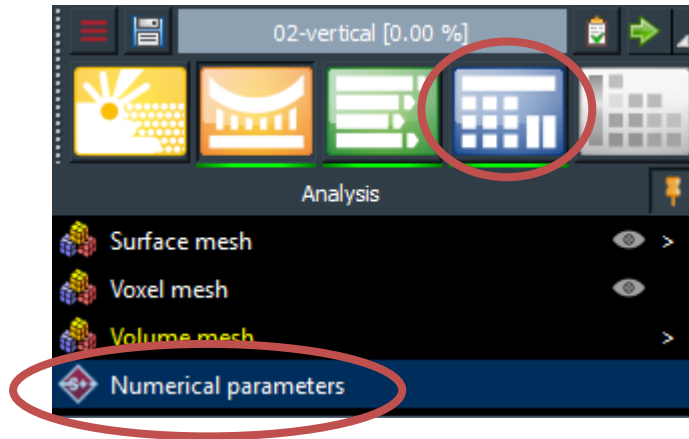

- ◆ Improved reproducibility for highly sensitive simulations using Pardiso solver
- ◆ The numerical reproducibility for highly sensitive simulation using the Pardiso solver can be improved by activating the corresponding option in the advanced solver settings

Further improvements

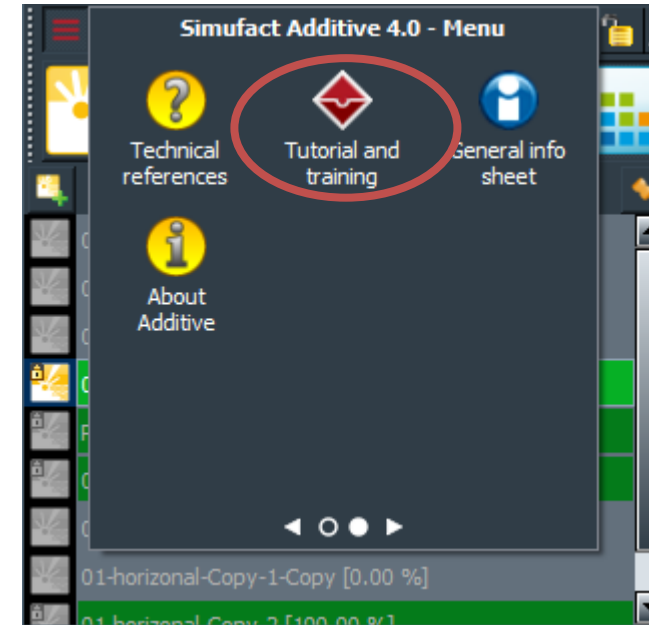
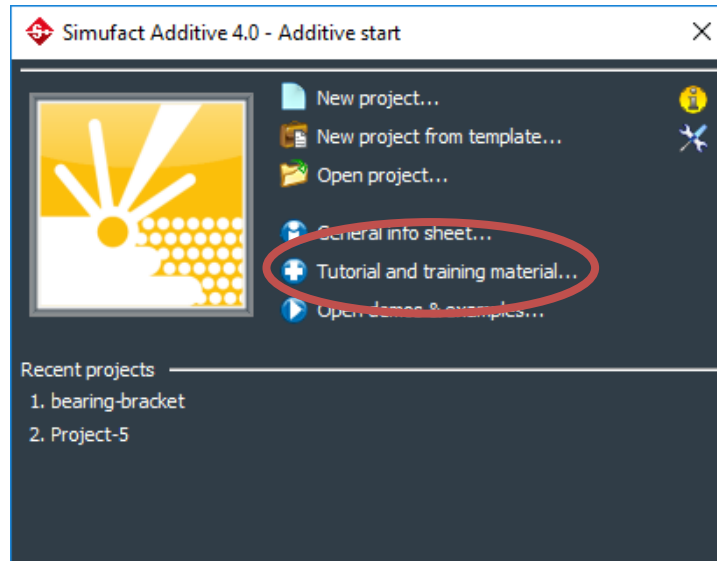

- ◆ Renamed „Tutorial“ to „Tutorial and training material“ so that the documents are more clearly named

Further improvements

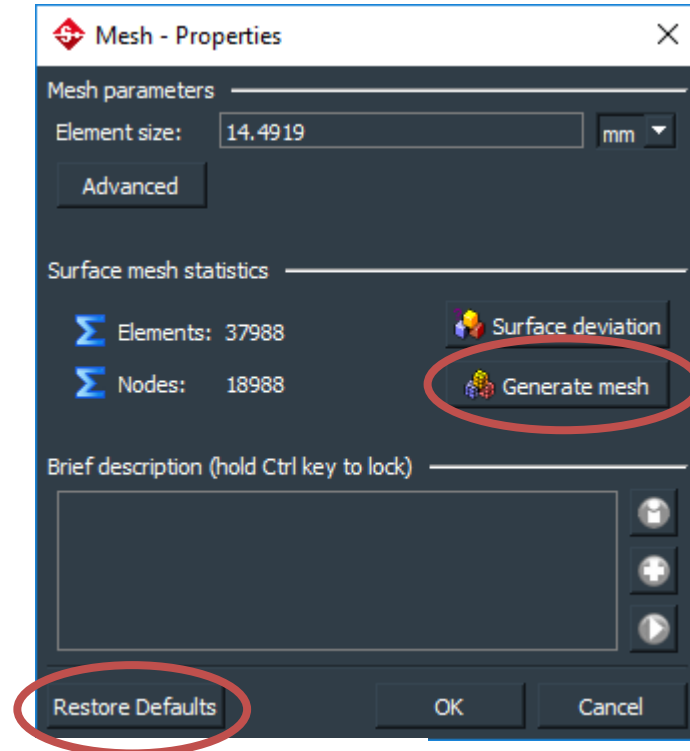

- ◆ **Decreased the number of buttons per dialog**
- ◆ Removed „Apply“ and „Reset“ buttons in all dialogs
- ◆ Special dialogs now have a „Restore defaults“ button which changes the values back to the default values
- ◆ Buttons with special functions like „Create mesh“ were added to dialogs where needed
- ◆ Avoids the usage of „Apply“ button for functions like mesh generation

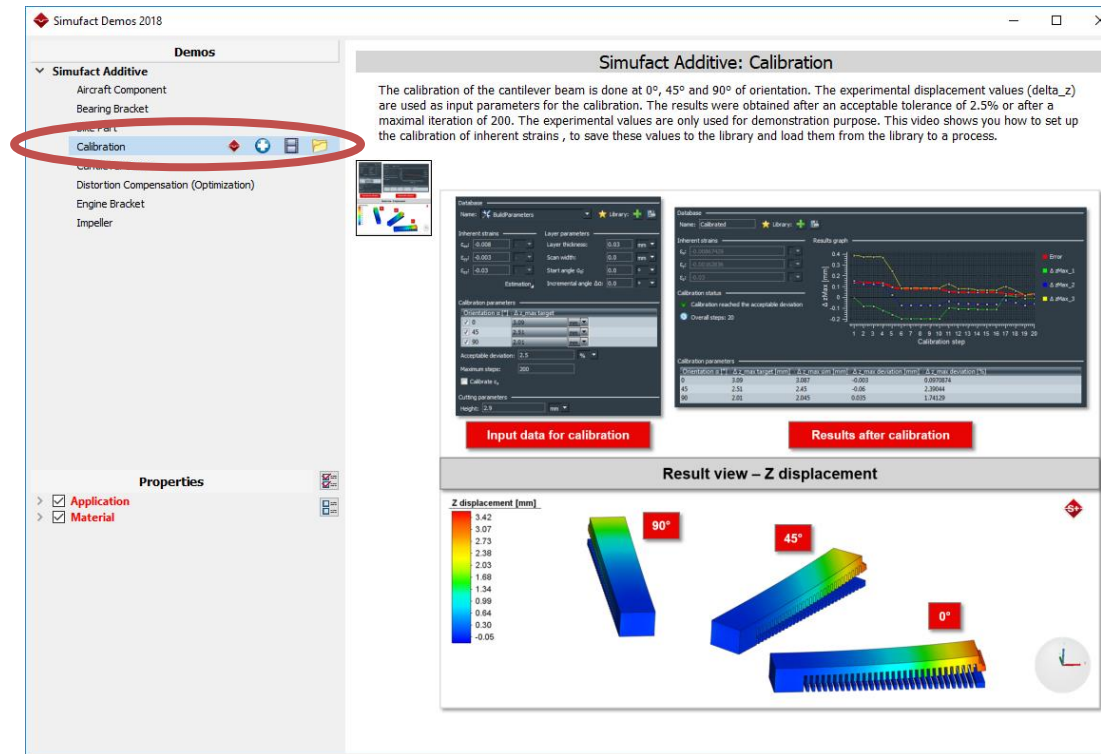

- ◆ **Reworked GUI design of Simufact Demos to be more user-friendly and reduce mouse movements**
- ◆ Buttons to open the project, tutorial, movie or directory are now located near the selected demo entry
- ◆ If one entry does not contain e.g. a tutorial file, the corresponding button will not be shown

Further improvements

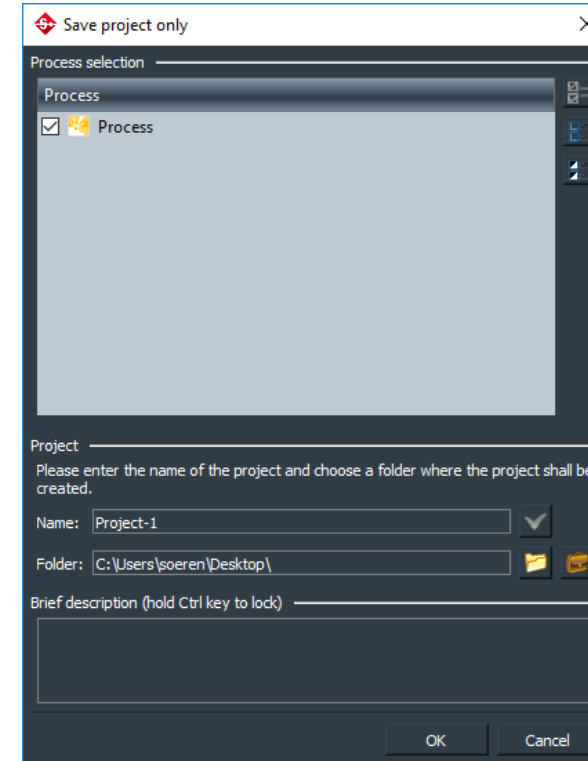
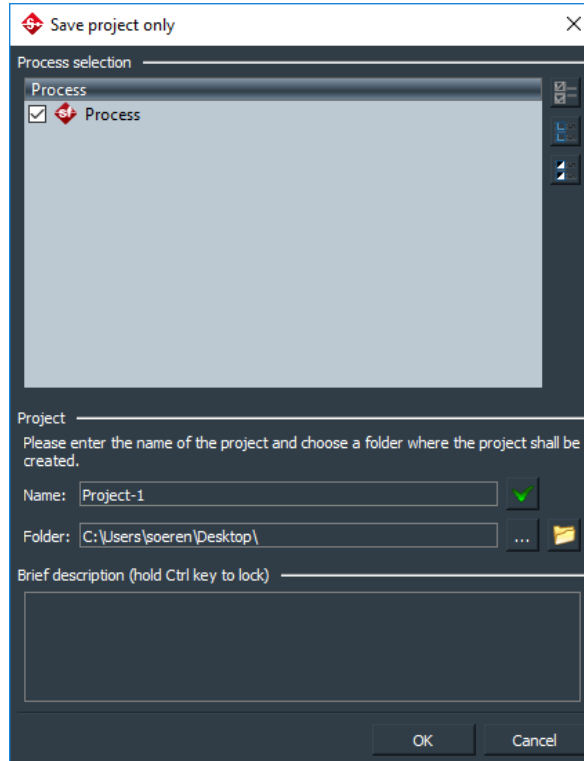

- ◆ Redesigned „Save as“ dialog to use common icons and be more user-friendly
- ◆ The last used „save as“ path will be used for the next „save as“

Further improvements

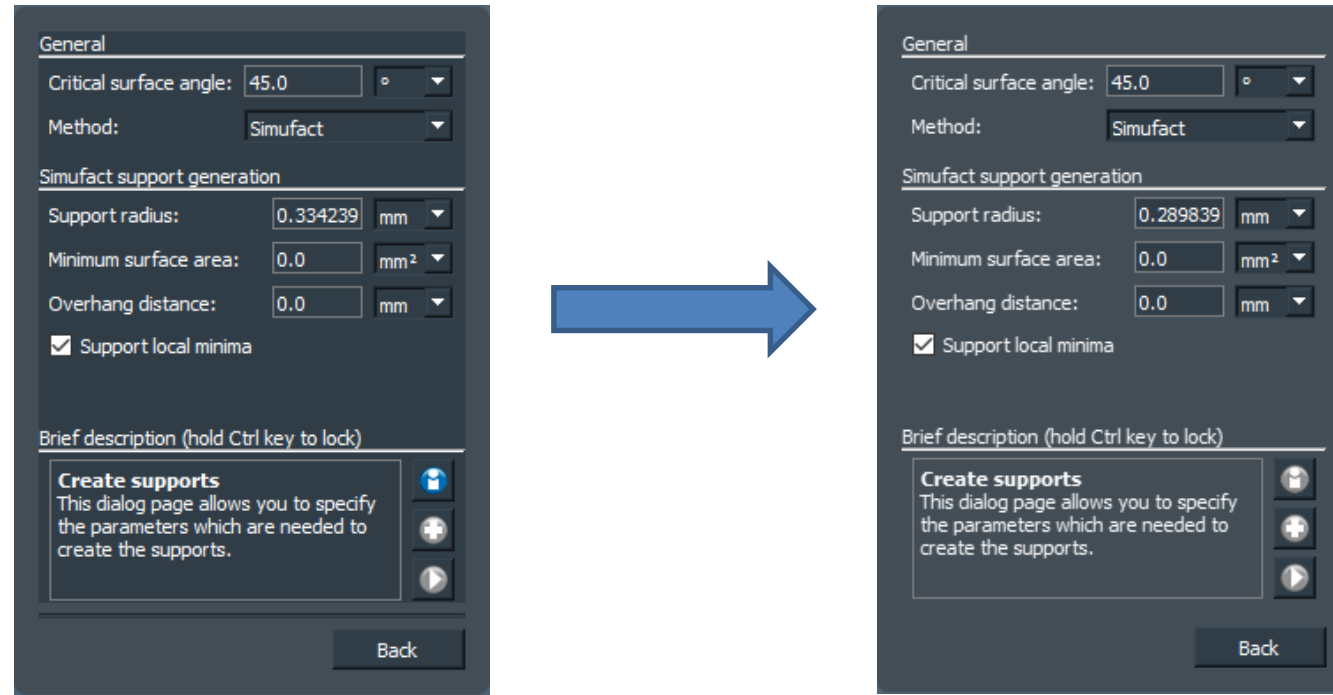

- ◆ Changed **style of support parameter dialog** in orientation assistant to be uniform with orientation assistant dialog

Further improvements

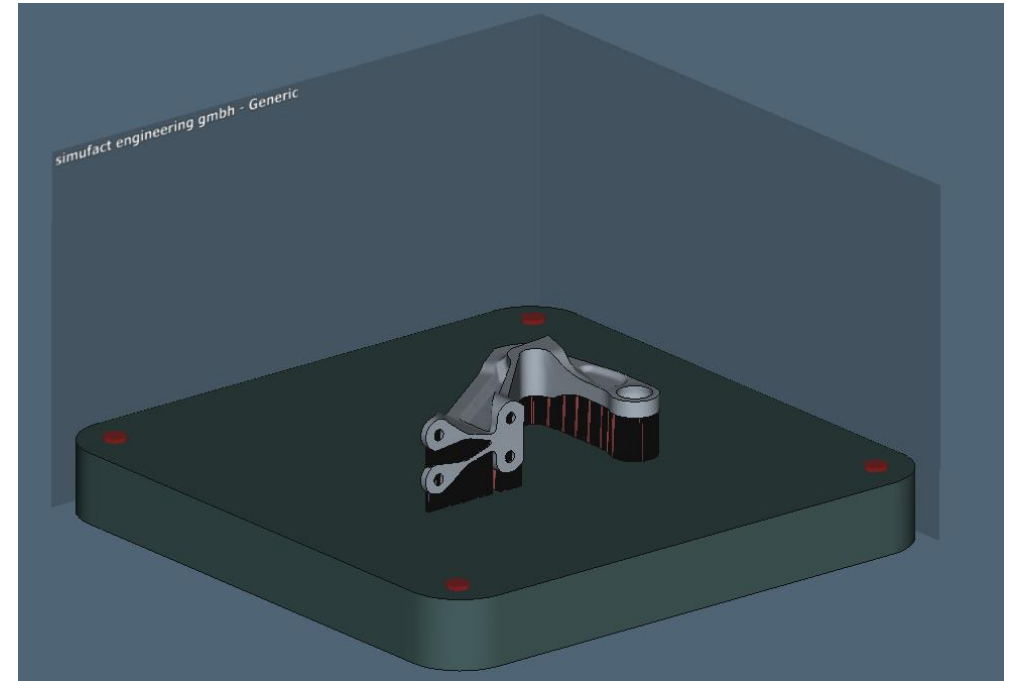
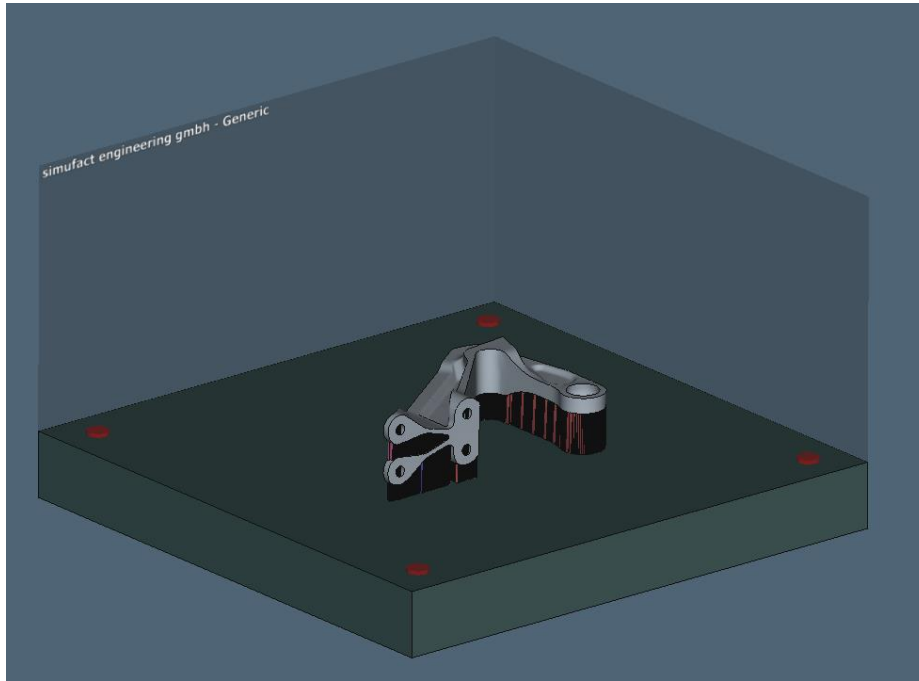

- ◆ **Changed base plate shape** of all base plates in library to be more realistic

Further improvements

- ◆ Improved messages in thermal and thermomechanical build properties dialog to inform the user why a specific value is not available

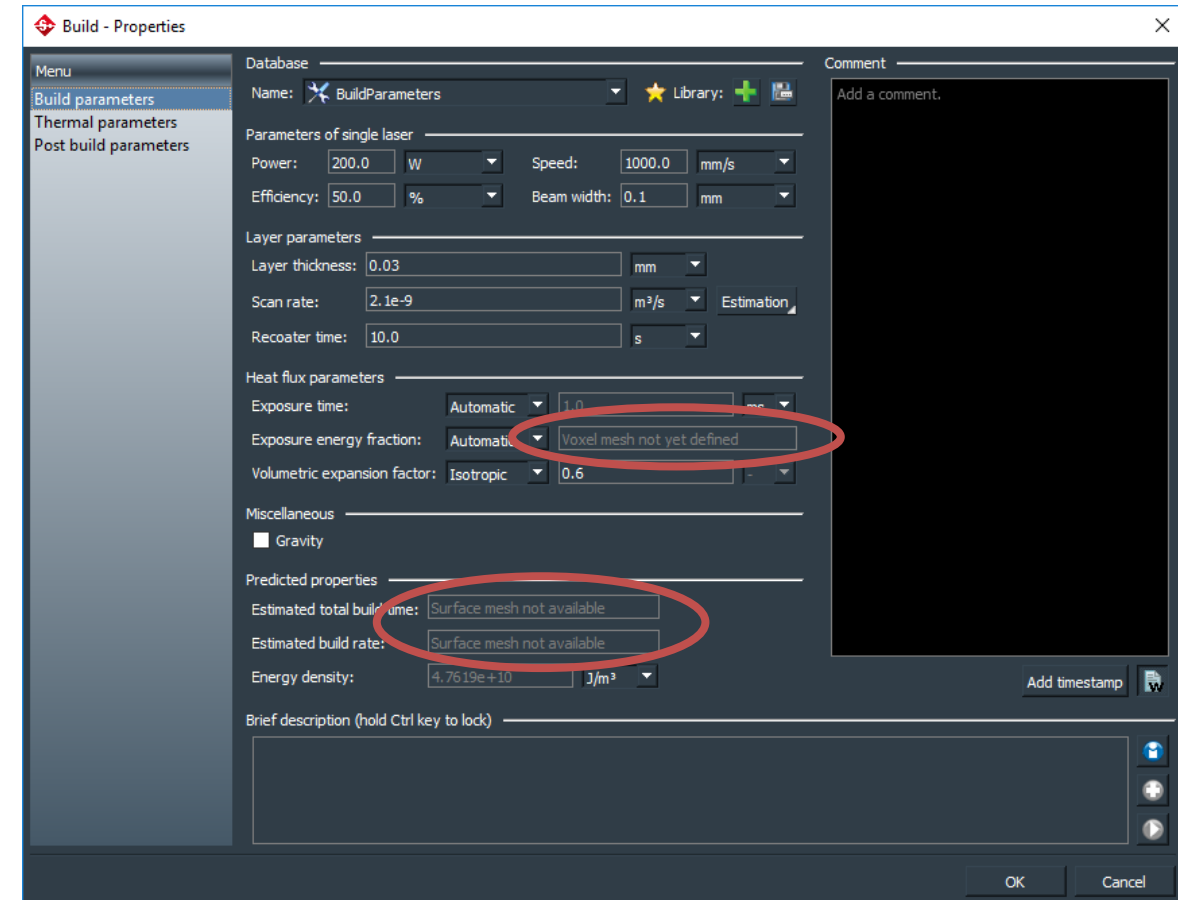

Further improvements

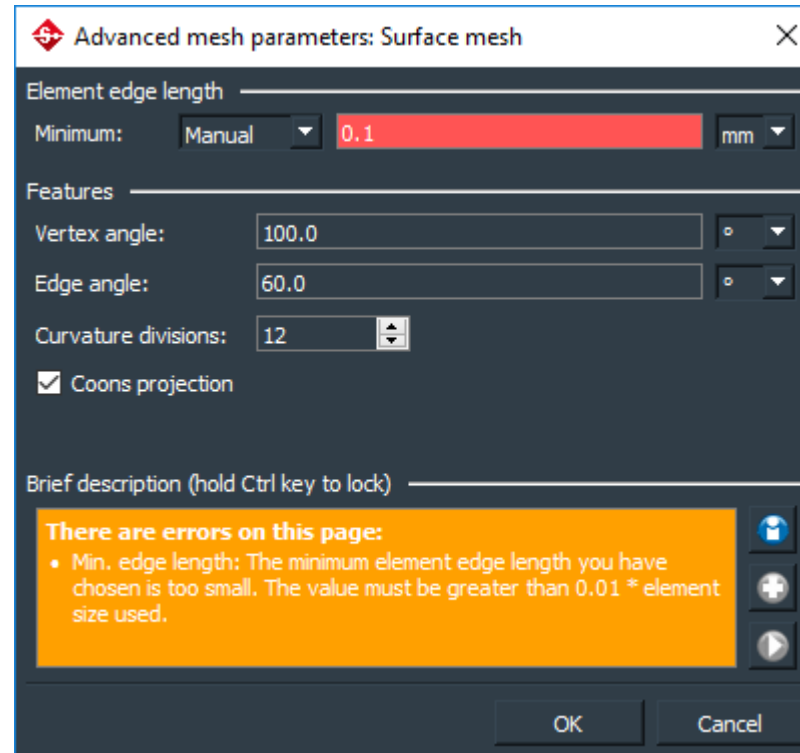

- ◆ **Avoid meshing issues due to too small minimum element edge length** in advanced mesh parameters dialog for surface mesh and volume mesh by setting a minimum allowed value of 1% of nominal element size
- ◆ Values below 1% are shown as errors in the dialog

Further improvements

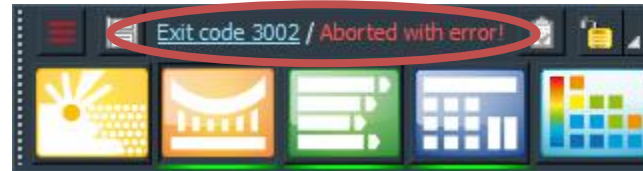

- ◆ **Linked info sheet about exit codes** to message in main widget
- ◆ Allows fast and easy access to info sheet as well as reasons and suggestions for corresponding exit code in simulation

Further improvements

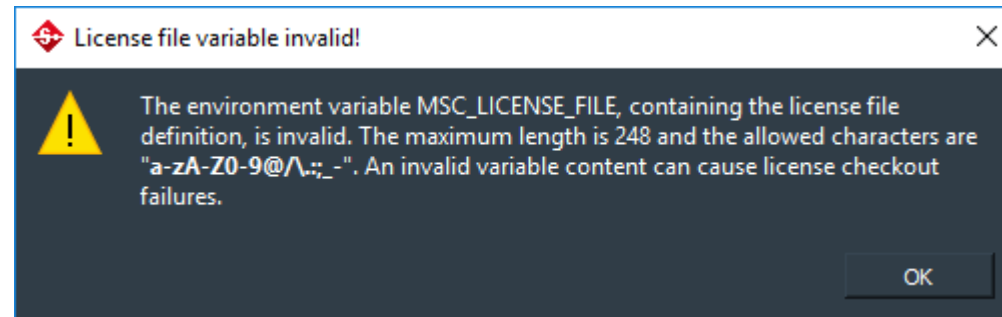
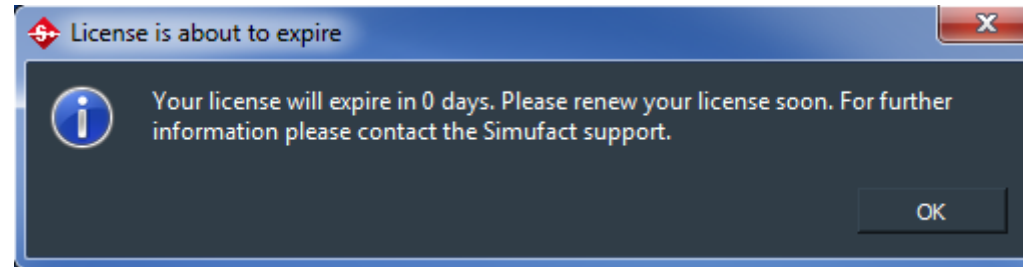

- ◆ User will be reminded when the license is going to expire
- ◆ A warning is shown if the license path contains invalid characters

Further improvements

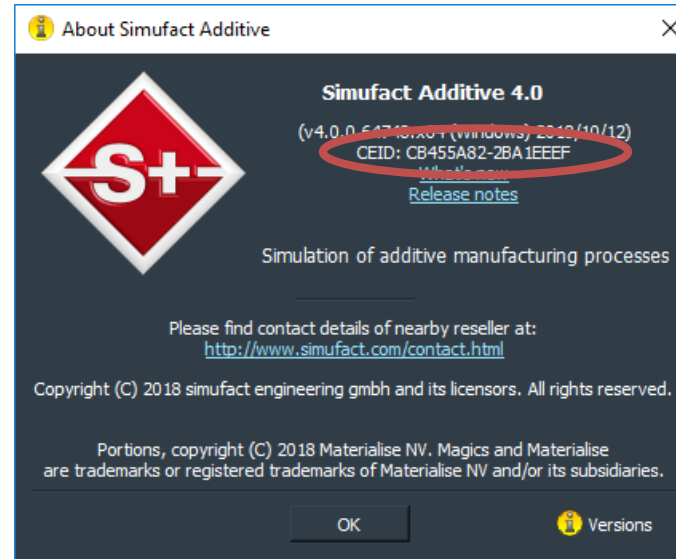

- ◆ Customer entitlement ID (CEID) can be seen in the about dialog
- ◆ The CEID can be requested during a support case

Further improvements

When deleting a running simulation:

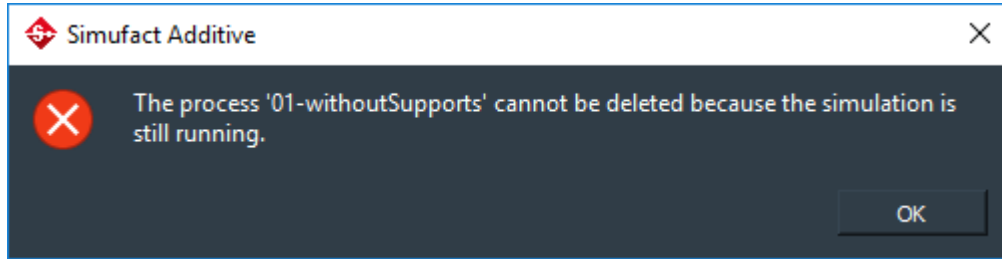

When deleting a process with results:

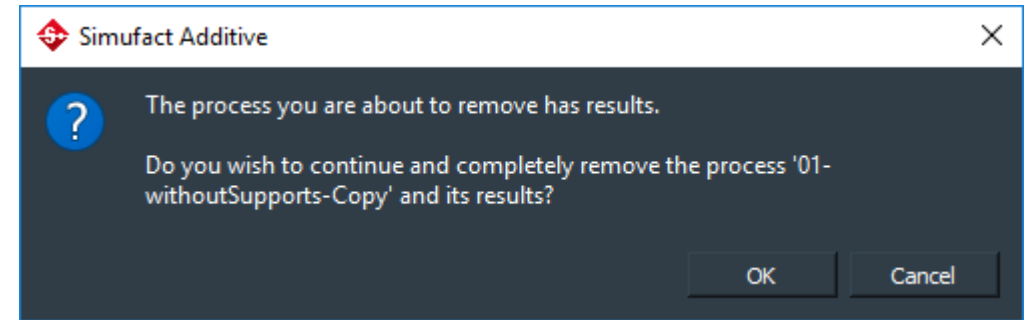

When deleting results:

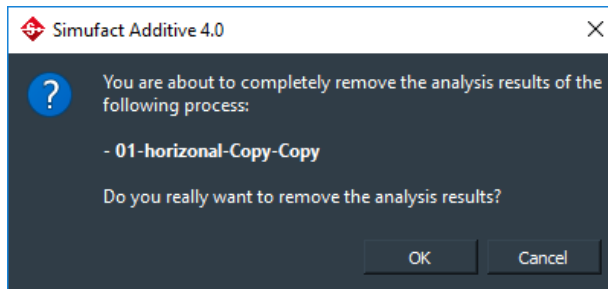

When deleting a process without results:

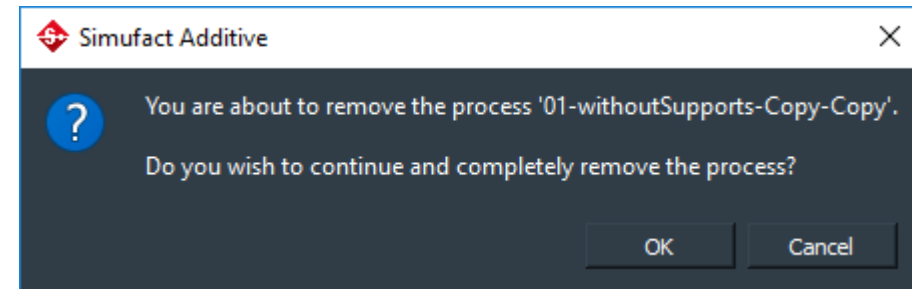

◆ Unified message boxes with other Simufact products

Further improvements

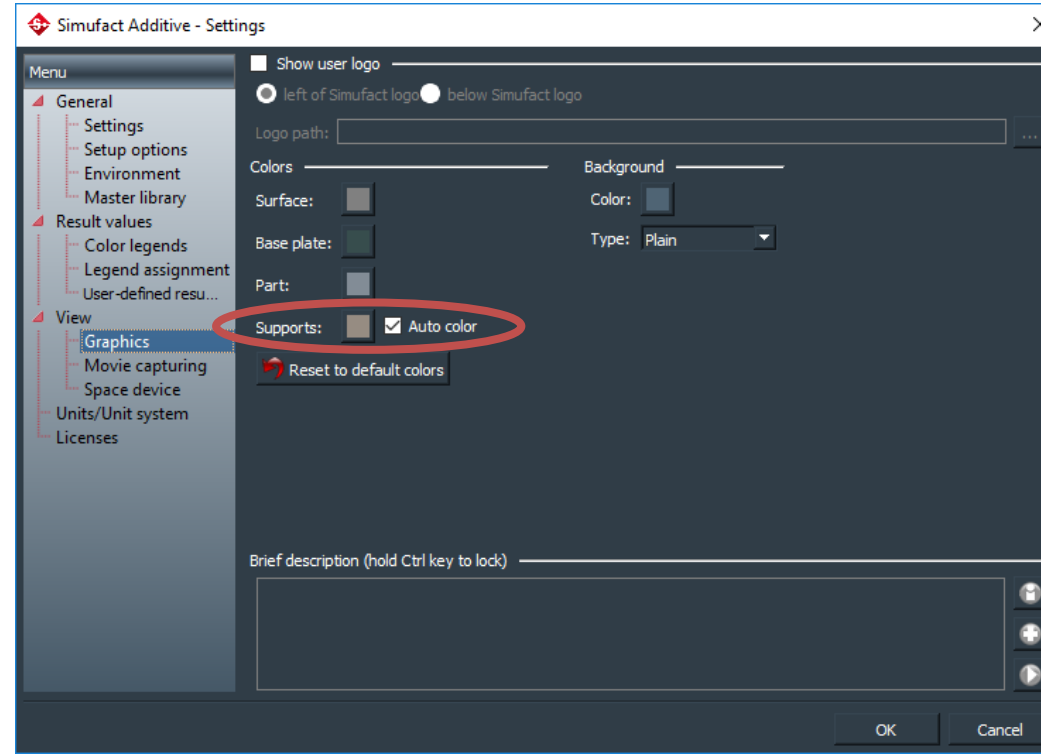

- ◆ Auto color for supports option is now located in the settings

Further improvements

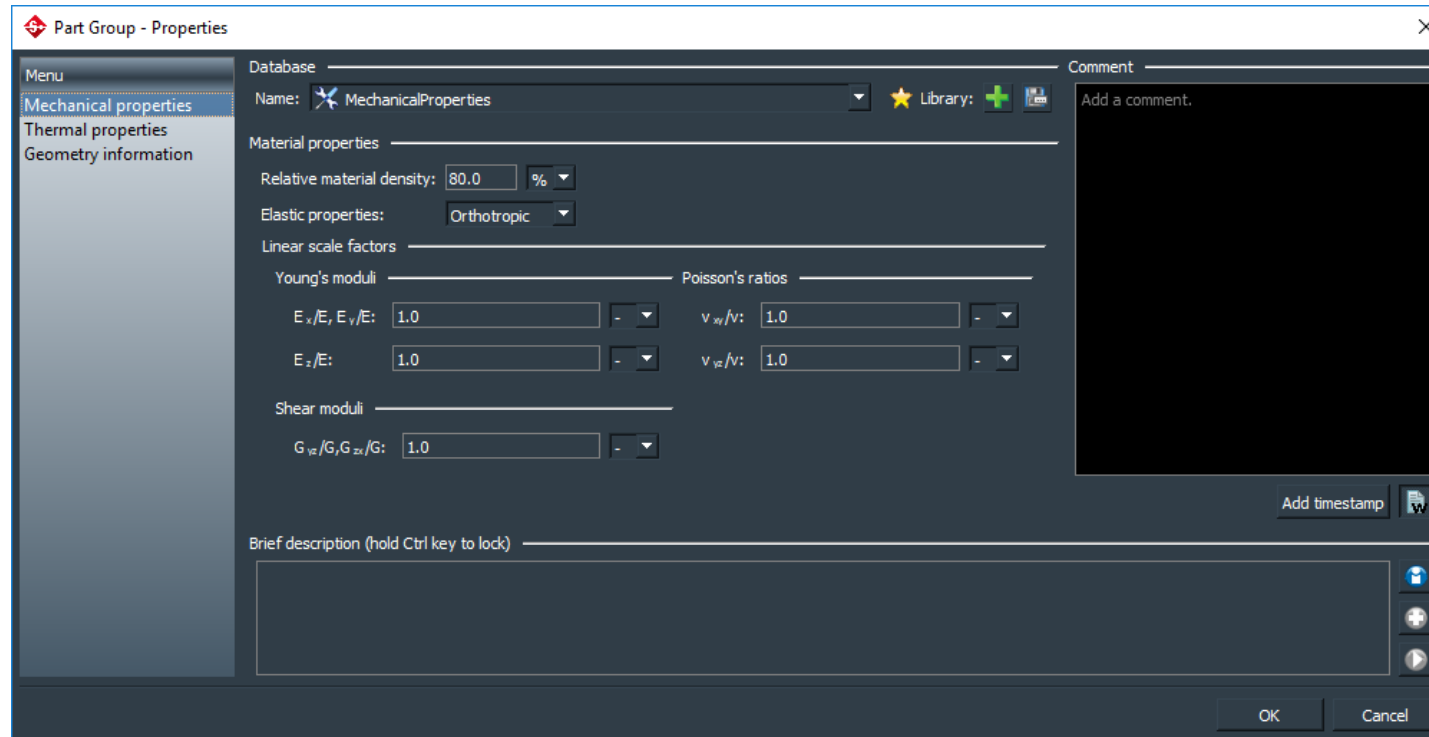

- ◆ Improved design for orthotropic mechanical and thermal support parameters
- ◆ Reduced text in front of input fields and grouped values

Further improvements

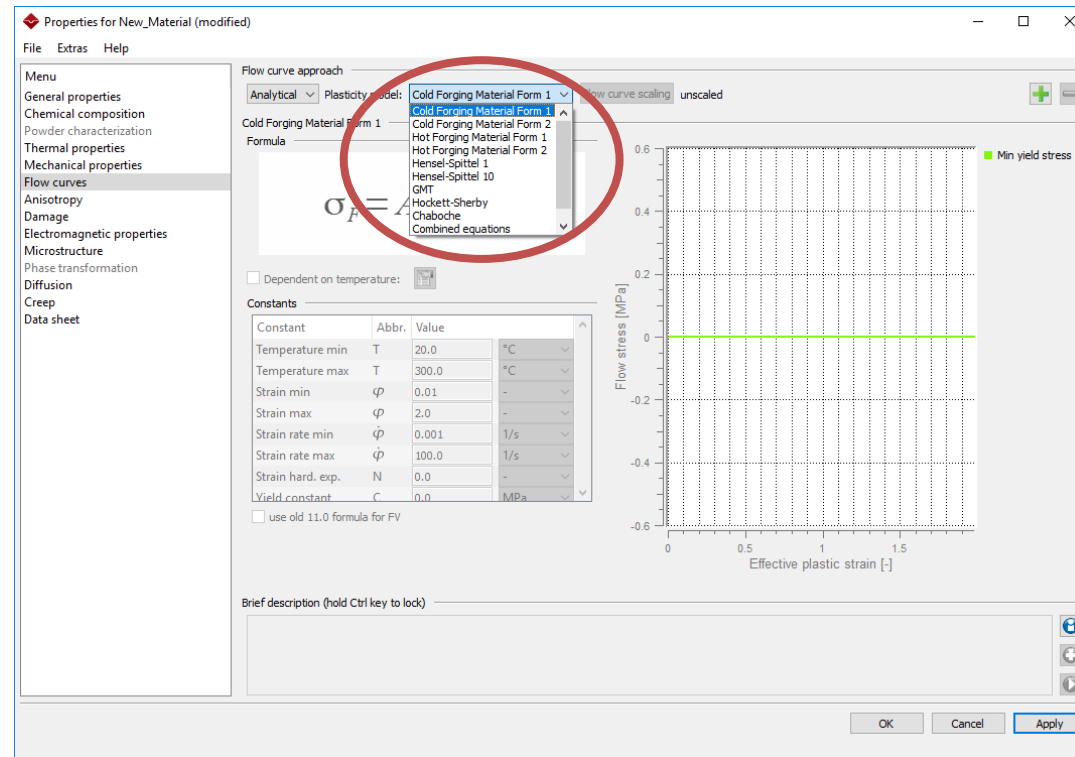

- ◆ Reordered dropdown menu for plasticity model in Simufact Material to a more common style

Further improvements

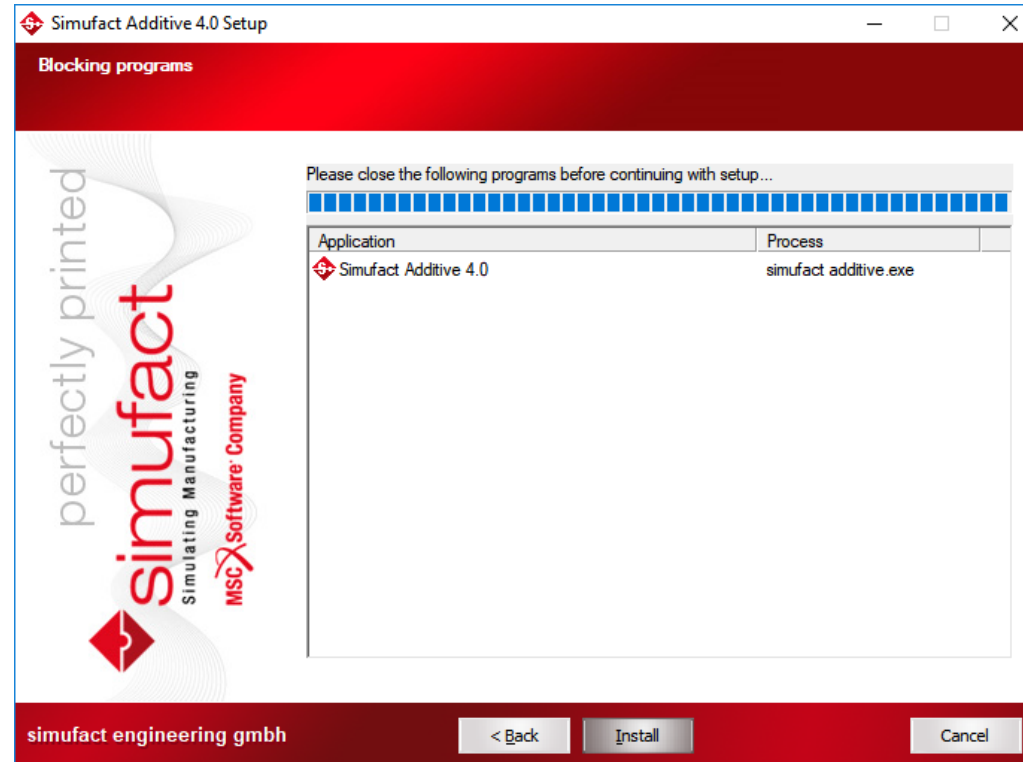

- ◆ Avoid installation problems by showing a list of blocking programs during setup

Further improvements

01-thermal-analysis.sts - Editor

Datei Bearbeiten Format Ansicht ?

job name : 01-thermal-analysis

inc	load_case_name	tot_time	cycl	conv_r	conv_d	cycl	conv_r	prg(%)	pst	rst
0	Initializing	0.0000E+00	0	0.000E+00	0.000E+00	0	0.000E+00	10.00	0	0
0	Initializing	0.0000E+00	0	0.000E+00	0.000E+00	0	0.000E+00	40.00	0	0
0	Initializing	0.0000E+00	0	0.000E+00	0.000E+00	0	0.000E+00	70.00	0	0
0	Initializing	0.0000E+00	0	0.000E+00	0.000E+00	0	0.000E+00	100.00	0	0
0	Start simulation	0.0000E+00	0	0.000E+00	0.000E+00	0	0.000E+00	0.00	0	0
1	AM_Layer 1	1.0000E-03	0	0.000E+00	0.000E+00	4	4.062E-01	0.00	1	0
2	AM_Layer 1	1.7676E-01	0	0.000E+00	0.000E+00	51	1.048E+01	0.00	1	0
3	AM_Layer 1	5.2827E-01	0	0.000E+00	0.000E+00	6	7.883E-01	0.00	1	0
4	AM_Layer 1	1.0555E+00	0	0.000E+00	0.000E+00	4	3.978E-01	0.00	1	0
5	AM_Layer 1	1.7586E+00	0	0.000E+00	0.000E+00	3	3.776E-01	0.00	1	0
6	AM_Layer 1	2.6374E+00	0	0.000E+00	0.000E+00	2	8.518E-01	0.00	1	0
7	AM_Layer 1	3.6919E+00	0	0.000E+00	0.000E+00	2	5.838E-01	0.00	1	0
8	AM_Layer 1	4.9222E+00	0	0.000E+00	0.000E+00	2	4.369E-01	0.00	1	0
9	AM_Layer 1	6.3283E+00	0	0.000E+00	0.000E+00	2	3.237E-01	0.00	1	0
10	AM_Layer 1	7.9101E+00	0	0.000E+00	0.000E+00	2	2.377E-01	0.01	1	0
11	AM_Layer 1	9.6677E+00	0	0.000E+00	0.000E+00	2	1.728E-01	0.01	1	0
12	AM_Layer 1	1.1601E+01	0	0.000E+00	0.000E+00	2	1.252E-01	0.01	1	0
13	AM_Layer 1	1.1062E+03	0	0.000E+00	0.000E+00	2	2.893E-01	0.79	13	0
14	AM_Layer 1	1.7729E+03	0	0.000E+00	0.000E+00	2	2.364E-01	1.26	14	0
15	AM_Layer 2	1.7729E+03	0	0.000E+00	0.000E+00	4	9.319E-01	1.26	15	0
16	AM_Layer 2	1.7731E+03	0	0.000E+00	0.000E+00	51	1.819E+01	1.26	15	0
17

- ◆ Added number of **cycles** for **thermal pass** and **thermal convergency** to **status file**

Further improvements

```
$-----  
$ Connectivity of model: allParts  
$ Hexahedrals: 27154  
$ Number of all elements: 27154  
$ Number of nodes: 33730  
$ Area: 0.366579  
$ Volume: 9.16447e-5  
$ Bounding box from: [0.05975, 0.07925, 0] to: [0.17825, 0.15875, 0.039]  
$-----
```

- ◆ When mesh is outsourced to ARC file, **mesh information** will be written to **DAT file**

- ◆ **Improved performance when opening projects**
- ◆ **Improved view performance** for large models when picking mode is active
- ◆ **Improved warning about small dimensions** of imported geometry
- ◆ **Distortion compensation is deactivated** for purely **thermal simulations**
- ◆ **Displacement scaling factor is fixed to one** when opening shape comparison
- ◆ **Keyboard shortcuts harmonized** for all Simufact products
- ◆ **Warning message** about not available support surface results **is only shown when results are mapped**
- ◆ **Remote test scripts added to setup**
- ◆ **ArcTool and ArcToolCmd added to setup**
- ◆ **Relative support volume** option was removed from support properties
- ◆ **Status bar was removed** from Additive GUI

Further improvements

- ◆ Added **temperature-dependent material properties** for **MS1**
- ◆ Added **ultimate strength** and **yield strength to powder materials**
- ◆ **Unified handling of object names** for all Simufact products



Where Simulation Gets Real